

# HP LaserJet P2030 Series Printer

## User Guide

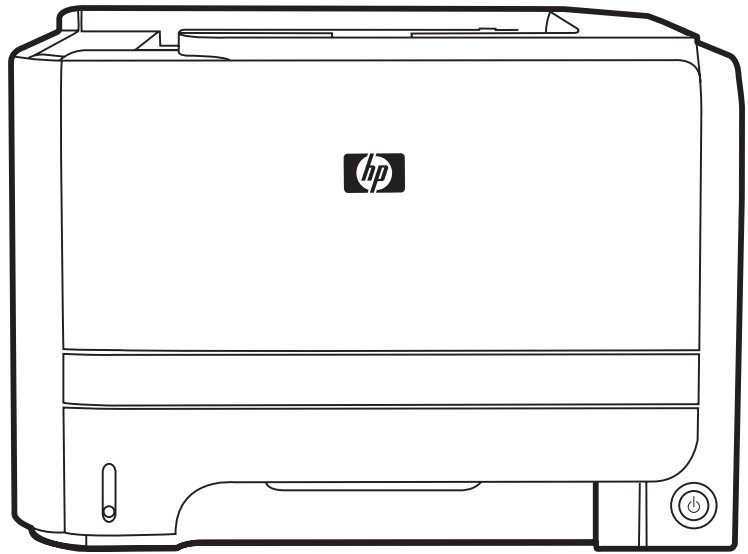



HP LaserJet P2030 Series Printer  
User Guide



## Copyright and License

© 2008 Copyright Hewlett-Packard Development Company, L.P.

Reproduction, adaptation, or translation without prior written permission is prohibited, except as allowed under the copyright laws.

The information contained herein is subject to change without notice.

The only warranties for HP products and services are set forth in the express warranty statements accompanying such products and services. Nothing herein should be construed as constituting an additional warranty. HP shall not be liable for technical or editorial errors or omissions contained herein.

Part number: CE461-90902

Edition 1, 10/2008

## Trademark Credits

Adobe®, Acrobat®, and PostScript® are trademarks of Adobe Systems Incorporated.

Intel® Core™ is a trademark of Intel Corporation in the U.S. and other countries.

Microsoft®, Windows®, and Windows®XP are U.S. registered trademarks of Microsoft Corporation.

Windows Vista™ is either a registered trademark or trademark of Microsoft Corporation in the United States and/or other countries.

UNIX® is a registered trademark of The Open Group.

ENERGY STAR and the ENERGY STAR mark are registered U.S. marks.

---

# Table of contents

## 1 Product basics

Product comparison .....	2
HP LaserJet P2030 Series models .....	2
Product features .....	3
Product walkaround .....	4
Front view .....	4
Rear view .....	5
Interface ports .....	6
Model and serial-number label location .....	7

## 2 Control panel

## 3 Software for Windows

Supported operating systems for Windows .....	12
Supported printer drivers for Windows .....	12
Priority for print settings .....	13
Change printer-driver settings for Windows .....	14
Remove software for Windows .....	14
Supported utilities for Windows .....	15
Status Alerts software .....	15
Supported network utilities for Windows .....	15
Embedded Web server .....	15
Software for other operating systems .....	15

## 4 Use the product with Macintosh

Software for Macintosh .....	18
Supported operating systems for Macintosh .....	18
Change printer-driver settings for Macintosh .....	18
Software for Macintosh computers .....	19
HP Printer Utility .....	19
Open the HP Printer Utility .....	19
Supported utilities for Macintosh .....	19
Embedded Web server .....	19
Use features in the Macintosh printer driver .....	20

Print .....	20
Create and use printing presets in Macintosh .....	20
Resize documents or print on a custom paper size .....	20
Print a cover page .....	20
Use watermarks .....	21
Print multiple pages on one sheet of paper in Macintosh .....	21
Print on both sides of the page (duplex printing) .....	22
Use the Services menu .....	22

## 5 Connectivity

USB and parallel connections .....	24
Network configuration .....	25
Supported network protocols .....	25
Install the product on a network .....	26
Configure the network product .....	26
View or change network settings .....	26
Set or change the network password .....	27
IP address .....	27
Link speed setting .....	27

## 6 Paper and print media

Understand paper and print media use .....	30
Supported paper and print media sizes .....	31
Custom paper sizes .....	32
Supported paper and print media types .....	33
Tray and bin capacity .....	34
Special paper or print media guidelines .....	35
Load trays .....	36
Paper orientation for loading trays .....	36
Tray 1 .....	37
Tray 2 .....	38
Load A6-size paper .....	38
Manual feed .....	39
Configure trays .....	39
Use paper output options .....	40
Print to the top (standard) output bin .....	40
Print to the straight-through paper path (rear output) .....	41

## 7 Use product features

EconoMode .....	44
Quiet mode .....	45

## 8 Print tasks

Cancel a print job .....	48
Stop the current print job from the control panel .....	48
Stop the current print job from the software program .....	48
Use features in the Windows printer driver .....	49
Open the printer driver .....	49
Use Quick Sets .....	49
Set paper and quality options .....	50
Set document effects .....	50
Set document finishing options .....	51
Obtain support and product-status information .....	52
Set advanced printing options .....	53

## 9 Manage and maintain the product

Print the information pages .....	56
Demo page .....	56
Configuration page .....	56
Supplies Status page .....	56
Manage a network product .....	57
Embedded Web server .....	57
Open the embedded Web server .....	57
Information tab .....	57
Settings tab .....	58
Networking tab .....	58
Links .....	58
Secure the embedded Web server .....	58
Lock the product .....	59
Manage supplies .....	60
Supplies life .....	60
Manage the print cartridge .....	60
Print-cartridge storage .....	60
Use genuine HP print cartridges .....	60
HP policy on non-HP print cartridges .....	60
Print-cartridge authentication .....	60
HP fraud hotline and Web site .....	60
Replace supplies and parts .....	62
Supply replacement guidelines .....	62
Redistribute toner .....	62
Change the print cartridge .....	63
Clean the product .....	65
Clean the print-cartridge area .....	65
Clean the paper path .....	67
Clean the Tray 1 pickup roller .....	68
Clean the Tray 2 pickup roller .....	72

## 10 Solve problems

Solve general problems .....	76
Troubleshooting checklist .....	76
Factors that affect product performance .....	77
Restore factory settings .....	77
Status-light patterns .....	78
Status-alert messages .....	84
Jams .....	86
Common causes of jams .....	86
Jam locations .....	87
Clear jams .....	87
Internal areas .....	87
Print-cartridge area and paper path .....	87
Input trays .....	89
Tray 1 .....	89
Tray 2 .....	90
Output bins .....	92
Solve print-quality problems .....	94
Print-quality problems associated with paper .....	94
Print-quality problems associated with the environment .....	94
Print-quality problems associated with jams .....	94
Adjust print density .....	95
Image defect examples .....	96
Light print or faded .....	96
Toner specks .....	96
Dropouts .....	96
Vertical lines .....	97
Gray background .....	97
Toner smear .....	97
Loose toner .....	97
Vertical repetitive defects .....	98
Misformed characters .....	98
Page skew .....	98
Curl or wave .....	98
Wrinkles or creases .....	99
Toner scatter outline .....	99
Solve performance problems .....	100
Solve connectivity problems .....	101
Solve direct-connect problems .....	101
Solve network problems .....	101
Solve common Windows problems .....	103
Solve common Macintosh problems .....	104
Solve Linux problems .....	106



## Appendix A Supplies and accessories

Order parts, accessories, and supplies .....	108
Order directly from HP .....	108
Order through service or support providers .....	108
Part numbers .....	109
Print cartridges .....	109
Cables and interfaces .....	109

## Appendix B Service and support

Hewlett-Packard limited warranty statement .....	112
Print cartridge limited warranty statement .....	113
End User License Agreement .....	114
Customer self-repair warranty service .....	116
Customer support .....	117
HP maintenance agreements .....	118
On-site service agreements .....	118
Next-day on-site service .....	118
Weekly (volume) on-site service .....	118
Repack the product .....	118
Extended warranty .....	118

## Appendix C Specifications

Physical specifications .....	120
Power consumption and acoustic emissions .....	120
Operating environment .....	120

## Appendix D Regulatory information

FCC regulations .....	122
Environmental product stewardship program .....	123
Protecting the environment .....	123
Ozone production .....	123
Power consumption .....	123
Toner consumption .....	123
Paper use .....	123
Plastics .....	123
HP LaserJet print supplies .....	123
Return and recycling instructions .....	124
United States and Puerto Rico .....	124
Multiple returns (more than one cartridge) .....	124
Single returns .....	124
Shipping .....	124
Non-U.S. returns .....	124
Paper .....	124

Material restrictions .....	124
Disposal of waste equipment by users in private households in the European Union .....	125
Material Safety Data Sheet (MSDS) .....	125
For more information .....	125
Declaration of conformity .....	126
Declaration of conformity .....	126
Safety statements .....	127
Laser safety .....	127
Canadian DOC regulations .....	127
VCCI statement (Japan) .....	127
Power cord statement (Japan) .....	127
EMI statement (Korea) .....	127
Laser statement for Finland .....	128
Substances Table (China) .....	129
<b>Index .....</b>	<b>131</b>

---

# 1 Product basics

- [Product comparison](#)
- [Product features](#)
- [Product walkaround](#)

# Product comparison

## HP LaserJet P2030 Series models

---

### HP LaserJet P2035 printer

CE461A

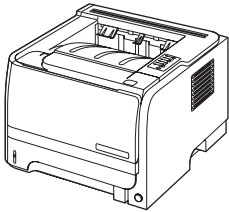

### HP LaserJet P2035n printer

CE462A

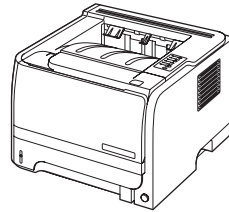

- 
- |  |   |
|--|---|
| <ul style="list-style-type: none"><li>● Prints up to 30 pages per minute (ppm) on Letter-size paper and 30 ppm on A4-size paper</li><li>● Contains 16 megabytes (MB) of random access memory (RAM).</li><li>● HP print cartridge, rated for up to 1,000 pages</li><li>● Tray 1 holds up to 50 sheets</li><li>● Tray 2 holds up to 250 sheets</li><li>● 125-sheet face-down output bin</li><li>● Straight-through output path</li><li>● Hi-speed USB 2.0 port</li><li>● Parallel port</li></ul> | <p>Has the same features as the HP LaserJet P2035 model, with the following differences:</p> <ul style="list-style-type: none"><li>● On-board networking</li><li>● No parallel port</li></ul> |
|--|---|
-

# Product features

Feature	Description
<b>Performance</b>	<ul style="list-style-type: none"><li>● 266 MHz processor</li></ul>
<b>User interface</b>	<ul style="list-style-type: none"><li>● 2-button, 6 LED control panel</li><li>● Windows® and Macintosh printer drivers</li><li>● Embedded Web server to access support and order supplies (for network-connected models only)</li></ul>
<b>Printer drivers</b>	<ul style="list-style-type: none"><li>● Host-based printer drivers for Windows and Macintosh, included on the product CD</li><li>● HP UPD PCL 5 printer driver, available for download from the Web</li><li>● XML Paper Specification (XPS) printer driver, available for download from the Web</li></ul>
<b>Resolution</b>	<ul style="list-style-type: none"><li>● FastRes 1200—produces 1200-dots-per-inch (dpi) print quality for fast, high-quality printing of business text and graphics</li><li>● 600 dpi—provides the fastest printing</li></ul>
<b>Fonts</b>	<ul style="list-style-type: none"><li>● 45 internal scalable fonts</li><li>● 80 device-matching screen fonts in TrueType format available with the software solution</li></ul>
<b>Connectivity</b>	<ul style="list-style-type: none"><li>● Hi-Speed USB 2.0 connection</li><li>● Parallel connection (HP LaserJet P2035 printer only)</li><li>● RJ.45 network connection (HP LaserJet P2035n printer only)</li></ul>
<b>Supplies</b>	<ul style="list-style-type: none"><li>● The supplies status page contains information about toner level, page count, and approximate pages remaining.</li><li>● The product checks for an authentic HP print cartridge at installation.</li><li>● Integration with HP Sure Supply Web site for easy replacement-cartridge reordering</li></ul>
<b>Accessories</b>	<ul style="list-style-type: none"><li>● HP Jetdirect external print server</li></ul>
<b>Supported operating systems</b>	<ul style="list-style-type: none"><li>● Microsoft® Windows® 2000, Windows® Server 2003, Windows® XP, and Windows Vista™</li><li>● Macintosh OS X V10.3, V10.4, V10.5, and later</li><li>● Unix®</li><li>● Linux</li></ul>
<b>Accessibility</b>	<ul style="list-style-type: none"><li>● The online user guide is compatible with text screen-readers.</li><li>● The print cartridge can be installed and removed by using one hand.</li><li>● All doors can be opened by using one hand.</li><li>● Paper can be loaded in Tray 1 by using one hand.</li></ul>

# Product walkaround

## Front view

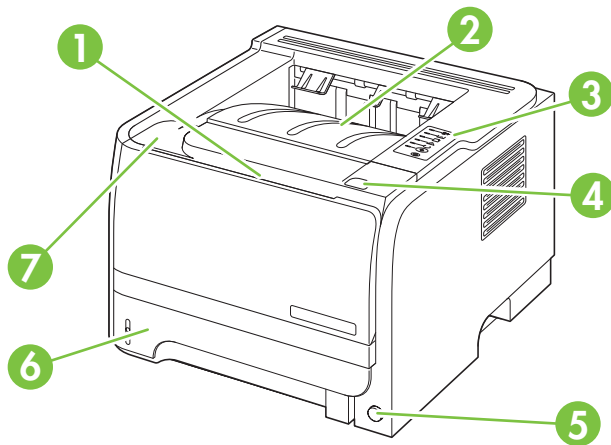

1	Tray 1 (pull to open)
2	Top output bin
3	Control panel
4	Print-cartridge-door release button
5	On/off switch
6	Tray 2
7	Print-cartridge door

## Rear view

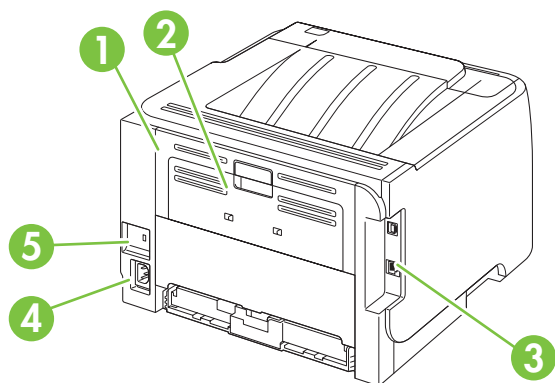

1	Jam-release door (pull the green handle to open)
2	Straight-through paper path (pull to open)
3	Interface ports
4	Power connection
5	Slot for a cable-type security lock

## Interface ports

**Figure 1-1** HP LaserJet P2035 printer

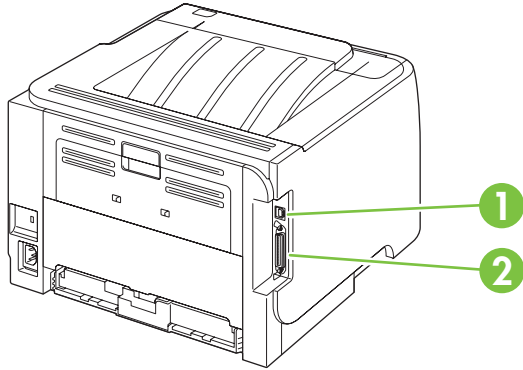

1	Hi-speed USB 2.0 port
2	Parallel port

**Figure 1-2** HP LaserJet P2035n printer

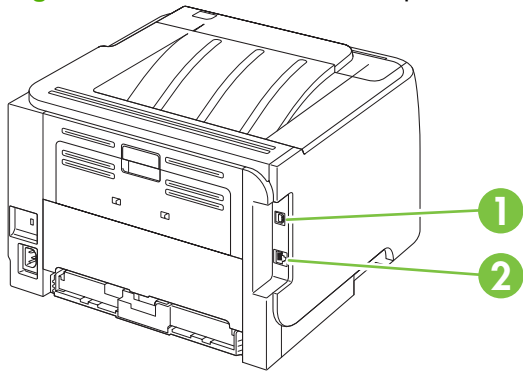

1	Hi-speed USB 2.0 port
2	RJ.45 network port



## Model and serial-number label location

The label that contains the model and serial numbers is on the rear of the product.

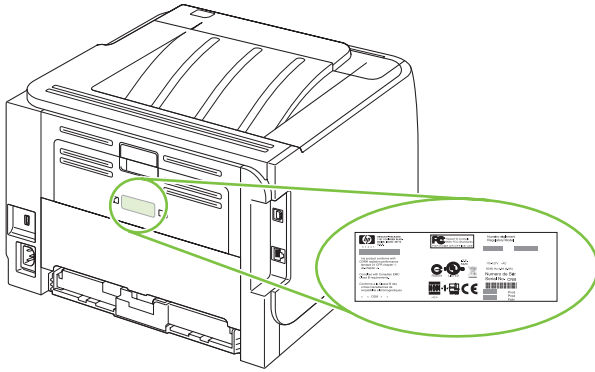



## 2 Control panel

The printer control panel is comprised of six lights and two buttons. The lights produce patterns that identify the printer status.

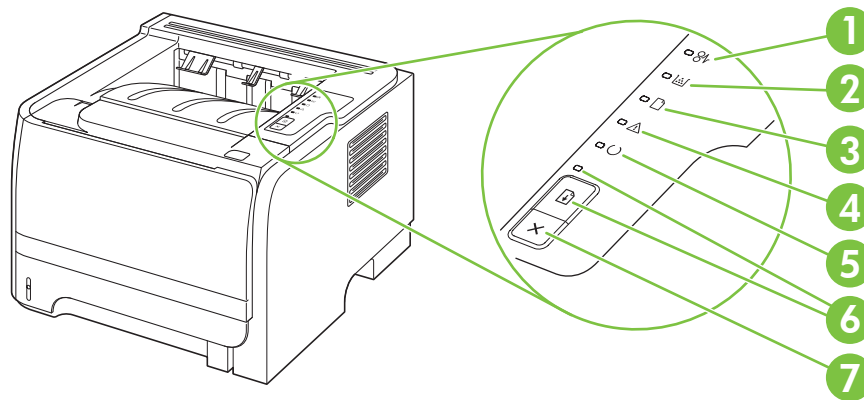

1	<b>Jam light:</b> Indicates a jam in the printer
2	<b>Toner light:</b> When the print cartridge is low, the Toner light illuminates. When the print cartridge is out of the printer, the Toner light blinks.
3	<b>Paper out light:</b> Indicates the printer is out of paper
4	<b>Attention light:</b> Indicates the print cartridge door is open or other errors exist
5	<b>Ready light:</b> Indicates the printer is ready to print
6	<b>Go button and light</b>
7	<b>Cancel button:</b> To cancel the print job currently printing, press the <b>Cancel</b> button.

 **NOTE:** See [Status-light patterns on page 78](#) for a description of the light patterns.



---

## 3 Software for Windows

- [Supported operating systems for Windows](#)
- [Supported printer drivers for Windows](#)
- [Priority for print settings](#)
- [Change printer-driver settings for Windows](#)
- [Remove software for Windows](#)
- [Supported utilities for Windows](#)
- [Supported network utilities for Windows](#)
- [Software for other operating systems](#)

## Supported operating systems for Windows

The product supports the following Windows operating systems:

- Windows XP (32-bit and 64-bit)
- Windows Server 2003 (32-bit and 64-bit)
- Windows 2000
- Windows Vista (32-bit and 64-bit)

## Supported printer drivers for Windows

The product features a host-based printer driver.

The printer driver includes online Help that has instructions for common printing tasks and also describes the buttons, check boxes, and drop-down lists that are in the printer driver.

# Priority for print settings

Changes to print settings are prioritized depending on where the changes are made:

 **NOTE:** The names of commands and dialog boxes might vary depending on your software program.

- **Page Setup dialog box:** Click **Page Setup** or a similar command on the **File** menu of the program you are working in to open this dialog box. Settings changed here override settings changed anywhere else.
- **Print dialog box:** Click **Print**, **Print Setup**, or a similar command on the **File** menu of the program you are working in to open this dialog box. Settings changed in the **Print** dialog box have a lower priority and do *not* override changes made in the **Page Setup** dialog box.
- **Printer Properties dialog box (printer driver):** Click **Properties** in the **Print** dialog box to open the printer driver. Settings changed in the **Printer Properties** dialog box do not override settings anywhere else in the printing software.
- **Default printer driver settings:** The default printer driver settings determine the settings used in all print jobs, *unless* settings are changed in the **Page Setup**, **Print**, or **Printer Properties** dialog boxes.

# Change printer-driver settings for Windows

---

Change the settings for all print jobs until the software program is closed	Change the default settings for all print jobs	Change the product configuration settings
<ol style="list-style-type: none"><li>1. On the <b>File</b> menu in the software program, click <b>Print</b>.</li><li>2. Select the driver, and then click <b>Properties</b> or <b>Preferences</b>.</li></ol> <p>The steps can vary; this procedure is most common.</p>	<ol style="list-style-type: none"><li>1. <b>Windows XP and Windows Server 2003 (using the default Start menu view):</b> Click <b>Start</b>, and then click <b>Printers and Faxes</b>.</li></ol> <p>-or-</p> <p><b>Windows 2000, Windows XP, and Windows Server 2003 (using the Classic Start menu view):</b> Click <b>Start</b>, click <b>Settings</b>, and then click <b>Printers</b>.</p> <p>-or-</p> <p><b>Windows Vista:</b> Click <b>Start</b>, click <b>Control Panel</b>, and then in the category for <b>Hardware and Sound</b> click <b>Printer</b>.<ol style="list-style-type: none"><li>2. Right-click the driver icon, and then select <b>Printing Preferences</b>.</li></ol></p>	<ol style="list-style-type: none"><li>1. <b>Windows XP and Windows Server 2003 (using the default Start menu view):</b> Click <b>Start</b>, and then click <b>Printers and Faxes</b>.</li></ol> <p>-or-</p> <p><b>Windows 2000, Windows XP, and Windows Server 2003 (using the Classic Start menu view):</b> Click <b>Start</b>, click <b>Settings</b>, and then click <b>Printers</b>.</p> <p>-or-</p> <p><b>Windows Vista:</b> Click <b>Start</b>, click <b>Control Panel</b>, and then in the category for <b>Hardware and Sound</b> click <b>Printer</b>.<ol style="list-style-type: none"><li>2. Right-click the driver icon, and then select <b>Properties</b>.</li><li>3. Click the <b>Device Settings</b> tab.</li></ol></p>

---

## Remove software for Windows

1. Click **Start**, and then click **All Programs**.
2. Click **HP**, and then click the product name.
3. Click the option to uninstall the product, and then follow the onscreen instructions to remove the software.



# Supported utilities for Windows

## Status Alerts software

The Status Alerts software provides information about the current status of the product.

The software also provides pop-up alerts when certain events occur, such as an empty tray or a problem with the product. The alert includes information about solving the problem.

# Supported network utilities for Windows

## Embedded Web server

The device is equipped with an embedded Web server, which provides access to information about device and network activities. This information appears in a Web browser, such as Microsoft Internet Explorer, Netscape Navigator, Apple Safari, or Firefox.

The embedded Web server resides on the device. It is not loaded on a network server.

The embedded Web server provides an interface to the device that anyone who has a network-connected computer and a standard Web browser can use. No special software is installed or configured, but you must have a supported Web browser on your computer. To gain access to the embedded Web server, type the IP address for the device in the address line of the browser. (To find the IP address, print a configuration page. For more information about printing a configuration page, see [Print the information pages on page 56.](#))

For a complete explanation of the features and functionality of the embedded Web server, see [Embedded Web server on page 57.](#)

# Software for other operating systems

OS	Software
UNIX	To download the HP UNIX modelscripts, follow these steps. <ol style="list-style-type: none"><li>1. Go to <a href="http://www.hp.com">www.hp.com</a>, and click <b>Software &amp; Driver Download</b>.</li><li>2. Type the name of the product in the product name box.</li><li>3. In the list of operating systems, click <b>UNIX</b>.</li><li>4. Download the appropriate file or files.</li></ol>
Linux	For information, go to <a href="http://www.hp.com/go/linuxprinting">www.hp.com/go/linuxprinting</a> .



---

## 4 Use the product with Macintosh

- [Software for Macintosh](#)
- [Use features in the Macintosh printer driver](#)

# Software for Macintosh

## Supported operating systems for Macintosh

The product supports the following Macintosh operating systems:

- Mac OS X V10.3, V10.4, V10.5, and later

 **NOTE:** For Mac OS X V10.4 and later, PPC and Intel® Core™ Processor Macs are supported.

## Change printer-driver settings for Macintosh

Change the settings for all print jobs until the software program is closed	Change the default settings for all print jobs	Change the product configuration settings
<ol style="list-style-type: none"><li>1. On the <b>File</b> menu, click <b>Print</b>.</li><li>2. Change the settings that you want on the various menus.</li></ol>	<ol style="list-style-type: none"><li>1. On the <b>File</b> menu, click <b>Print</b>.</li><li>2. Change the settings that you want on the various menus.</li><li>3. On the <b>Presets</b> menu, click <b>Save as</b> and type a name for the preset.</li></ol> <p>These settings are saved in the <b>Presets</b> menu. To use the new settings, you must select the saved preset option every time you open a program and print.</p>	<p><b>Mac OS X V10.3 or Mac OS X V10.4</b></p> <ol style="list-style-type: none"><li>1. From the Apple menu, click <b>System Preferences</b> and then <b>Print &amp; Fax</b>.</li><li>2. Click <b>Printer Setup</b>.</li><li>3. Click the <b>Installable Options</b> menu.</li></ol> <p><b>Mac OS X V10.5</b></p> <ol style="list-style-type: none"><li>1. From the Apple menu, click <b>System Preferences</b> and then <b>Print &amp; Fax</b>.</li><li>2. Click <b>Options &amp; Supplies</b>.</li><li>3. Click the <b>Driver</b> menu.</li><li>4. Select the driver from the list, and configure the installed options.</li></ol>

## Software for Macintosh computers

### HP Printer Utility

Use the HP Printer Utility to set up product features that are not available in the printer driver.

You can use the HP Printer Utility when the product uses a universal serial bus (USB) cable or is connected to a TCP/IP-based network.

#### Open the HP Printer Utility

---

Mac OS X V10.3 or Mac OS X V10.4	<ol style="list-style-type: none"><li>1. Open the Finder, click <b>Applications</b>, click <b>Utilities</b>, and then double-click <b>Printer Setup Utility</b>.</li><li>2. Select the product that you want to configure, and then click <b>Utility</b>.</li></ol>
Mac OS X V10.5	<ol style="list-style-type: none"><li>1. From the <b>Printer</b> menu, click <b>Printer Utility</b>.</li></ol> <p>-or-</p> <p>From the <b>Print Queue</b>, click the <b>Utility</b> icon.</p>

---

## Supported utilities for Macintosh

### Embedded Web server

The device is equipped with an embedded Web server, which provides access to information about device and network activities. This information appears in a Web browser, such as Microsoft Internet Explorer, Netscape Navigator, Apple Safari, or Firefox.

The embedded Web server resides on the device. It is not loaded on a network server.

The embedded Web server provides an interface to the device that anyone who has a network-connected computer and a standard Web browser can use. No special software is installed or configured, but you must have a supported Web browser on your computer. To gain access to the embedded Web server, type the IP address for the device in the address line of the browser. (To find the IP address, print a configuration page. For more information about printing a configuration page, see [Print the information pages on page 56](#).)

For a complete explanation of the features and functionality of the embedded Web server, see [Embedded Web server on page 57](#).

# Use features in the Macintosh printer driver

## Print

### Create and use printing presets in Macintosh

Use printing presets to save the current printer driver settings for reuse.

#### Create a printing preset

1. On the **File** menu, click **Print**.
2. Select the driver.
3. Select the print settings.
4. In the **Presets** box, click **Save As...**, and type a name for the preset.
5. Click **OK**.

#### Use printing presets

1. On the **File** menu, click **Print**.
2. Select the driver.
3. In the **Presets** box, select the printing preset that you want to use.

---

 **NOTE:** To use printer-driver default settings, select **Standard**.

---

### Resize documents or print on a custom paper size

You can scale a document to fit on a different size of paper.

1. On the **File** menu, click **Print**.
2. Open the **Paper Handling** menu.
3. In the area for **Destination Paper Size**, select **Scale to fit paper size**, and then select the size from the drop-down list.
4. If you want to use only paper that is smaller than the document, select **Scale down only**.

### Print a cover page

You can print a separate cover page for your document that includes a message (such as “Confidential”).

1. On the **File** menu, click **Print**.
2. Select the driver.
3. Open the **Cover Page** menu, and then select whether to print the cover page **Before Document** or **After Document**.
4. In the **Cover Page Type** menu, select the message that you want to print on the cover page.

---

 **NOTE:** To print a blank cover page, select **Standard** as the **Cover Page Type**.

---

## Use watermarks

A watermark is a notice, such as “Confidential,” that is printed in the background of each page of a document.

1. On the **File** menu, click **Print**.
2. Open the **Watermarks** menu.
3. Next to **Mode**, select the type of watermark to use. Select **Watermark** to print a semi-transparent message. Select **Overlay** to print a message that is not transparent.
4. Next to **Pages**, select whether to print the watermark on all pages or on the first page only.
5. Next to **Text**, select one of the standard messages, or select **Custom** and type a new message in the box.
6. Select options for the remaining settings.

## Print multiple pages on one sheet of paper in Macintosh

You can print more than one page on a single sheet of paper. This feature provides a cost-effective way to print draft pages.

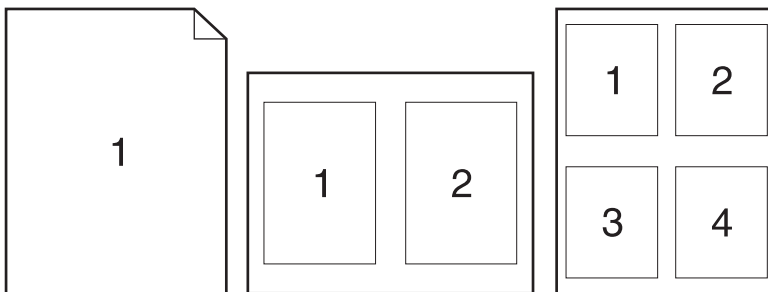

1. On the **File** menu, click **Print**.
2. Select the driver.
3. Open the **Layout** menu.
4. Next to **Pages per Sheet**, select the number of pages that you want to print on each sheet (1, 2, 4, 6, 9, or 16).
5. Next to **Layout Direction**, select the order and placement of the pages on the sheet.
6. Next to **Borders**, select the type of border to print around each page on the sheet.

## Print on both sides of the page (duplex printing)

### Print on both sides manually

1. Insert enough paper into one of the trays to accommodate the print job. If you are loading special paper such as letterhead, load it in one of the following ways:
  - For Tray 1, load the letterhead paper face-up with the top edge feeding into the product first.
  - For all other trays, load the letterhead paper face-down with the top edge at the front of the tray.
2. On the **File** menu, click **Print**.
3. On the **Finishing** menu, select **Manually Print on 2nd Side**.
4. Click **Print**. Follow the instructions in the pop-up window that appears on the computer screen before placing the output stack in Tray 1 for printing the second half.
5. Go to the product, and remove any blank paper that is in Tray 1.
6. Insert the printed stack face-up into Tray 1 with the top edge feeding into the product first. You *must* print the second side from Tray 1.
7. If prompted, press the appropriate control-panel button to continue.

### Use the Services menu

If the product is connected to a network, use the **Services** menu to obtain product and supply-status information.

1. On the **File** menu, click **Print**.
2. Open the **Services** menu.
3. To open the embedded Web server and perform a maintenance task, do the following:
  - a. Select **Device Maintenance**.
  - b. Select a task from the drop-down list.
  - c. Click **Launch**.
4. To go to various support Web sites for this device, do the following:
  - a. Select **Services on the Web**.
  - b. Select **Internet Services**, and select an option from the drop-down list.
  - c. Click **Go!**.



---

# 5 Connectivity

- [USB and parallel connections](#)
- [Network configuration](#)

## USB and parallel connections

1. Insert the software installation CD into the computer CD-ROM drive.
2. If the installation program does not start automatically, browse the CD contents and run the SETUP.EXE file.
3. Follow the on-screen instructions.

 **NOTE:** During the installation, there is a prompt to plug in the parallel or USB cable.

**Figure 5-1** Parallel connection

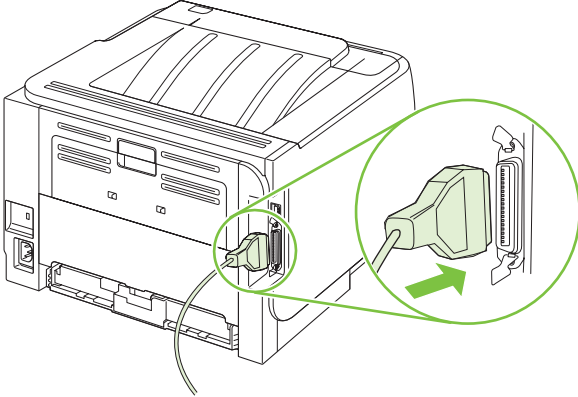

**Figure 5-2** USB connection

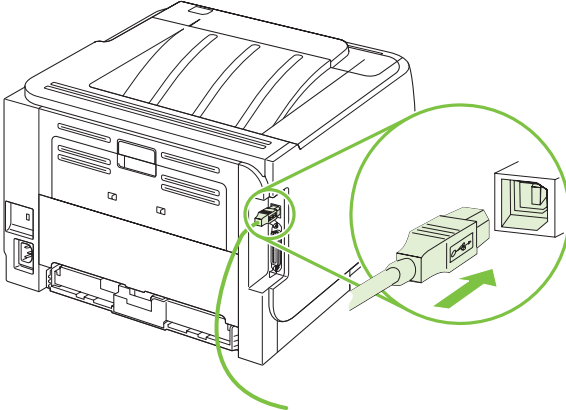

# Network configuration

You might need to configure certain network parameters on the product. You can configure these parameters from the embedded Web server. See [Embedded Web server on page 57](#).

## Supported network protocols

The product supports the TCP/IP network protocol. It is the most widely used and accepted networking protocol. Many networking services utilize this protocol. This product also supports IPv4 and IPv6. The following tables list the networking services/protocols that are supported on the product.

**Table 5-1 Printing**

Service name	Description
port9100 (Direct Mode)	Printing service
Line printer daemon (LPD)	Printing service

**Table 5-2 Network product discovery**

Service name	Description
SLP (Service Location Protocol)	Device Discovery Protocol, used to help find and configure network devices. Used primarily by Microsoft-based software programs.
mDNS (multicast Domain Name Service - also known as "Rendezvous" or "Bonjour")	Device Discovery Protocol, used to help find and configure network devices. Used primarily by Apple Macintosh-based software programs.

**Table 5-3 Messaging and management**

Service name	Description
HTTP (hypertext transfer protocol)	Allows Web browsers to communicate with embedded Web server.
EWS (embedded Web server)	Allows a user to manage the product through a Web browser.
SNMP (simple network management protocol)	Used by network programs for product management. SNMP V1, V2, and standard MIB-II (Management Information Base) objects are supported.

**Table 5-4 IP addressing**

Service name	Description
DHCP (dynamic host configuration protocol)	For Automatic IP address assignment. DHCP server provides the product with an IP address. Generally requires no user intervention for product to obtain IP address from a DHCP server.

**Table 5-4 IP addressing (continued)**

Service name	Description
BOOTP (bootstrap protocol)	For Automatic IP address assignment. BOOTP server provides the product with an IP address. Requires administrator to input the product MAC hardware address on BOOTP server in order for product to obtain an IP address from that server.
Auto IP	For Automatic IP address assignment. If neither a DHCP server nor a BOOTP server is present, this service allows the product to generate a unique IP address.

## Install the product on a network

In this configuration, the product is connected directly to the network and can be configured to allow all computers on the network to print directly to the product.

 **NOTE:** This mode is the recommended network configuration for the product.

1. Before turning on the product, connect the product directly to the network by inserting a network cable into the product network port.
2. Turn on the product, wait 2 minutes, and then use the control panel to print a configuration page.

 **NOTE:** Make sure that an IP address is listed on the configuration page before proceeding to the next step. If an IP address is not present, reprint the configuration page.

3. Insert the product CD into the computer. If the software installer does not start, navigate to the setup.exe file on the CD and double-click the file.
4. Follow the installer instructions.

 **NOTE:** When the installer prompts for a network address, provide the IP address listed on the configuration page that you printed before starting the installer program, or search for the product on the network.

5. Allow the installation process to complete.

## Configure the network product

### View or change network settings

You can use the embedded Web server to view or change IP configuration settings.

1. Print a configuration page, and locate the IP address.
  - If you are using IPv4, the IP address contains only digits. It has this format:  
`xx.xx.xx.xxx`
  - If you are using IPv6, the IP address is a hexadecimal combination of characters and digits. It has this format:  
`xxxx::xxx:xxxx:xxxx:xxxx`
2. Type the IP address into the address line of a Web browser to open the embedded Web server.
3. Click the **Networking** tab to obtain network information. You can change settings as needed.

## Set or change the network password

Use the embedded Web server to set a network password or change an existing password.

1. Open the embedded Web server and click the **Networking** tab.
2. In the left-side pane, click the **Password** button.

---

 **NOTE:** If a password has previously been set, you are prompted to type the password. Type the password, and then click the **Apply** button.

---

3. In the **Device Password** area, type the new password in the **Password** box and in the **Confirm Password** box.
4. At the bottom of the window, click the **Apply** button to save the password.

## IP address

The product IP address can be set manually, or it can be configured automatically via DHCP, BootP, or AutoIP.

To change the IP address manually, use the **Networking** tab in the embedded Web server.

## Link speed setting

Use the **Networking** tab in the embedded Web server to set the link speed if necessary.

Incorrect changes to the link speed setting might prevent the product from communicating with other network devices. For most situations, the product should be left in automatic mode. Changes can cause the product to power cycle. Changes should be made only while the product is idle.



---

## 6 Paper and print media

- [Understand paper and print media use](#)
- [Supported paper and print media sizes](#)
- [Custom paper sizes](#)
- [Supported paper and print media types](#)
- [Tray and bin capacity](#)
- [Special paper or print media guidelines](#)
- [Load trays](#)
- [Configure trays](#)
- [Use paper output options](#)

## Understand paper and print media use

This product supports a variety of paper and other print media in accordance with the guidelines in this user guide. Paper or print media that does not meet these guidelines might cause the following problems:

- Poor print quality
- Increased jams
- Premature wear on the product, requiring repair

For best results, use only HP-brand paper and print media designed for laser printers or multiuse. Do not use paper or print media made for inkjet printers. Hewlett-Packard Company cannot recommend the use of other brands of media because HP cannot control their quality.

It is possible for paper to meet all of the guidelines in this user guide and still not produce satisfactory results. This might be the result of improper handling, unacceptable temperature and/or humidity levels, or other variables over which Hewlett-Packard has no control.

---

△ **CAUTION:** Using paper or print media that does not meet Hewlett-Packard's specifications might cause problems for the product, requiring repair. This repair is not covered by the Hewlett-Packard warranty or service agreements.

---



# Supported paper and print media sizes

This product supports a number of paper sizes, and it adapts to various media.

 **NOTE:** To obtain best results, select the correct paper size and type in the printer driver before printing.

**Table 6-1 Supported paper and print media sizes**

Size and dimensions	Tray 1	Tray 2
Letter 216 x 279 mm (8.5 x 11 inches)	✓	✓
Legal 216 x 356 mm (8.5 x 14 inches)	✓	✓
A4 210 x 297 mm (8.27 x 11.69 inches)	✓	✓
A5 148 x 210 mm (5.83 x 8.27 inches)	✓	✓
A6 105 x 148 mm (4.1 x 5.8 inches)	✓	✓
B5 (JIS) 182 x 257 mm (7.17 x 10.12 inches)	✓	✓
Executive 184 x 267 mm (7.24 x 10.51 inches)	✓	✓
Postcard (JIS) 100 x 148 mm (3.9 x 5.8 inches)	✓	
Double Postcard (JIS) 148 x 200 mm (5.8 x 7.9 inches)	✓	
16K 184 x 260 mm (7.2 x 10.2 inches)	✓	
16K 195 x 270 mm (7.7 x 10.6 inches)	✓	
16K 197 x 273 mm (7.8 x 10.8 inches)	✓	
8.5 x 13 216 x 330 mm (8.5 x 13 inches)	✓	✓
Envelope Commercial #10 105 x 241 mm (4.13 x 9.49 inches)	✓	
Envelope B5 ISO	✓	

**Table 6-1 Supported paper and print media sizes (continued)**

Size and dimensions	Tray 1	Tray 2
176 x 250 mm (6.7 x 9.8 inches)		
Envelope C5 ISO	✓	
162 x 229 mm (6.93 x 9.84 inches)		
Envelope DL ISO	✓	
110 x 220 mm (4.33 x 8.66 inches)		
Envelope Monarch	✓	
98 x 191 mm (3.9 x 7.5 inches)		
Custom	✓	
76 x 127 mm to 216 x 356 mm (3.0 x 5.0 inches to 8.5 x 14 inches)		

## Custom paper sizes

This product supports a variety of custom paper sizes. Supported custom sizes are sizes that are within the minimum- and maximum-size guidelines for the product but are not listed in the supported paper sizes table. When using a supported custom size, specify the custom size in the print driver, and load the paper in a tray that supports custom sizes.

## Supported paper and print media types

For a complete list of specific HP-brand paper that this product supports, go to [www.hp.com/support/ljp2030series](http://www.hp.com/support/ljp2030series).

Paper type (printer driver)	Tray 1	Tray 2
Plain Paper	✓	✓
Light 60–74 g/m <sup>2</sup>	✓	✓
Midweight (96–110 g/m <sup>2</sup> )	✓	✓
Heavy (111–130 g/m <sup>2</sup> )	✓	✓
Extra Heavy (131–175 g/m <sup>2</sup> )	✓	
Transparency	✓	✓
Labels	✓	
Letterhead	✓	✓
Preprinted	✓	✓
Prepunched	✓	✓
Color	✓	✓
Rough	✓	✓
Bond	✓	✓
Recycled	✓	✓
Envelope	✓	
HP Multipurpose Paper	✓	✓
HP Office Paper	✓	✓
HP LaserJet Paper	✓	✓
HP Premium Choice Paper	✓	✓

## Tray and bin capacity

Tray or bin	Paper type	Specifications	Quantity
Tray 1	Paper	Range: 60 g/m <sup>2</sup> (16 lb) bond to 200 g/m <sup>2</sup> (54 lb) bond	Maximum stack height: 5 mm (0.3 inch) Equivalent to 50 sheets of 75 g/m <sup>2</sup> (20 lb) bond
	Envelopes	Less than 60 g/m <sup>2</sup> (16 lb) bond to 90 g/m <sup>2</sup> (24 lb) bond	Up to 10 envelopes
	Labels	Maximum 0.23 mm (0.009 inch) thick	Maximum stack height: 5 mm (0.3 inch)
	Transparencies	Minimum 0.13 mm (0.005 inch) thick	Maximum stack height: 5 mm (0.3 inch)
Tray 2	Paper	Range: 60 g/m <sup>2</sup> (16 lb) bond to 135 g/m <sup>2</sup> (36 lb) bond	Equivalent to 250 sheets of 75 g/m <sup>2</sup> (20 lb) bond Maximum stack height for A6 paper: 15 mm (0.59 inch)
	Transparencies	Minimum 0.13 mm (0.005 inch) thick	Maximum stack height: 26 mm (1.0 inch)
Standard top bin	Paper		Up to 125 sheets of 75 g/m <sup>2</sup> (20 lb) bond

# Special paper or print media guidelines

This product supports printing on special media. Use the following guidelines to obtain satisfactory results. When using special paper or print media, be sure to set the type and size in your print driver to obtain the best print results.

△ **CAUTION:** HP LaserJet printers use fusers to bond dry toner particles to the paper in very precise dots. HP laser paper is designed to withstand this extreme heat. Using inkjet paper not designed for this technology could damage your printer.

Media type	Do	Do not
Envelopes	<ul style="list-style-type: none"> <li>• Store envelopes flat.</li> <li>• Use envelopes where the seam extends all the way to the corner of the envelope.</li> <li>• Use peel-off adhesive strips that are approved for use in laser printers.</li> </ul>	<ul style="list-style-type: none"> <li>• Do not use envelopes that are wrinkled, nicked, stuck together, or otherwise damaged.</li> <li>• Do not use envelopes that have clasps, snaps, windows, or coated linings.</li> <li>• Do not use self-stick adhesives or other synthetic materials.</li> </ul>
Labels	<ul style="list-style-type: none"> <li>• Use only labels that have no exposed backing between them.</li> <li>• Use Labels that lie flat.</li> <li>• Use only full sheets of labels.</li> </ul>	<ul style="list-style-type: none"> <li>• Do not use labels that have wrinkles or bubbles, or are damaged.</li> <li>• Do not print partial sheets of labels.</li> </ul>
Transparencies	<ul style="list-style-type: none"> <li>• Use only transparencies that are approved for use in laser printers.</li> <li>• Place transparencies on a flat surface after removing them from the product.</li> </ul>	<ul style="list-style-type: none"> <li>• Do not use transparent print media not approved for laser printers.</li> </ul>
Letterhead or preprinted forms	<ul style="list-style-type: none"> <li>• Use only letterhead or forms approved for use in laser printers.</li> </ul>	<ul style="list-style-type: none"> <li>• Do not use raised or metallic letterhead.</li> </ul>
Heavy paper	<ul style="list-style-type: none"> <li>• Use only heavy paper that is approved for use in laser printers and meets the weight specifications for this product.</li> </ul>	<ul style="list-style-type: none"> <li>• Do not use paper that is heavier than the recommended media specification for this product unless it is HP paper that has been approved for use in this product.</li> </ul>
Glossy or coated paper	<ul style="list-style-type: none"> <li>• Use only glossy or coated paper that is approved for use in laser printers.</li> </ul>	<ul style="list-style-type: none"> <li>• Do not use glossy or coated paper designed for use in inkjet products.</li> </ul>

# Load trays

## Paper orientation for loading trays

If you are using paper that requires a specific orientation, load it according to the information in the following table.

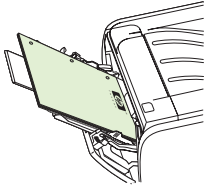
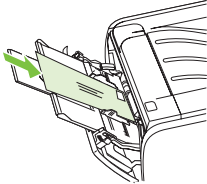
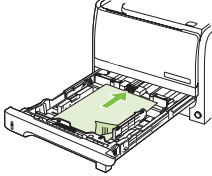
Tray	Single-sided printing	Envelope printing
Tray 1	Face-up Top edge leading into the product 	Front of envelope face-up Short edge with postage leading into the product 
Tray 2	Face-down Top edge at the front of the tray 	Use only Tray 1 for printing envelopes.

## Tray 1

Tray 1 is accessed from the front of the printer.

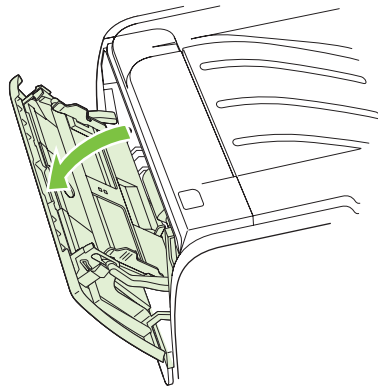

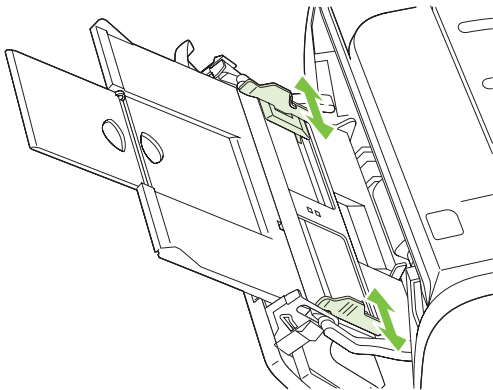

Media guides ensure that the media is correctly fed into the printer and that the print is not skewed (crooked on the media). When loading media, adjust the media guides to match the width of the media that you are using.

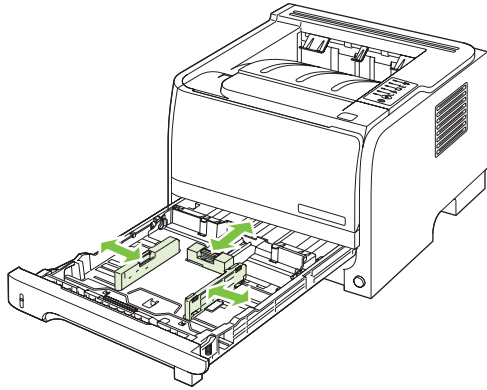

## Tray 2

Media guides ensure that the media feeds correctly into the printer and that the print is not skewed. Tray 2 has side and rear media guides. When loading media, adjust the media guides to match the length and width of the media that you are using.



 **NOTE:** When you add new media, make sure that you remove all of the media from the input tray and straighten the stack of new media. This reduces jams by preventing multiple sheets of media from feeding through the printer at one time.

## Load A6-size paper

When loading A6-size paper, adjust the length by sliding forward only the center panel of the rear media guide.

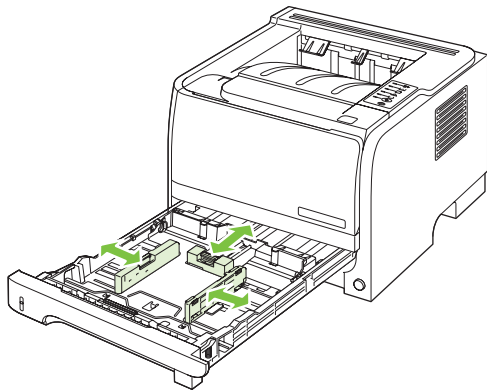



## Manual feed

You can use manual feed when printing mixed media. For example, you can use manual feed to print an envelope, then a letter, then an envelope, and so on. Load envelopes in Tray 1 and load letterhead into Tray 2.

To print using manual feed, open the printer Properties or Printer Setup, and then select **Manual Feed (tray 1)** from the **Source Tray** drop-down list. After you have enabled manual feed, press the **Go** button to print.

## Configure trays

Use either the printer driver or the embedded Web server to configure the trays for a particular paper type and size.

---

Printer driver	Click the <b>Paper/Quality</b> tab and select the type and size in the <b>Paper Options</b> area.
Embedded Web server	Click the <b>Settings</b> tab, and then click the <b>Paper Handling</b> option from the left-side pane.

---

## Use paper output options

The product has two output locations: the top (standard) output bin and the straight-through paper path (rear output).

### Print to the top (standard) output bin

The top output bin collects paper face-down, and in the correct order. The top output bin should be used for most print jobs, including transparencies. To use the top output bin, be sure that the straight-through paper path is closed. To avoid jams, do not open or close the straight-through paper path while the product is printing.

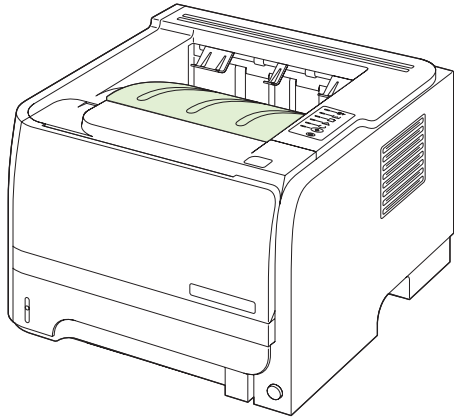

## Print to the straight-through paper path (rear output)

The product always uses the straight-through paper path if it is open. Paper exits face-up, with the last page on top (reverse order).

Printing from Tray 1 to the rear output provides the straightest path. Opening the straight-through paper path might improve performance with the following paper types:

- Envelopes
- Labels
- Small custom-size paper
- Postcards
- Paper heavier than 120 g/m<sup>2</sup> (32 lb)

To open the straight-through paper path, grasp the handle at the top of the rear door, and pull the door down.

 **NOTE:** Be sure to open the straight-through paper path, not the jam-release door.

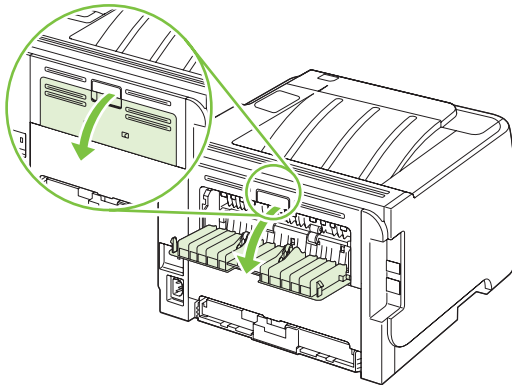



---

# 7 Use product features

- [EconoMode](#)
- [Quiet mode](#)

## EconoMode

This product has an EconoMode option for printing drafts of documents. Using EconoMode can use less toner and decrease the cost per page. However, using EconoMode can also reduce print quality.

HP does not recommend full-time use of EconoMode. If EconoMode is used full-time, the toner supply might outlast the mechanical parts in the print cartridge. If print quality begins to degrade under these circumstances, you will need to install a new print cartridge, even if there is toner supply remaining in the cartridge.

Enable or disable EconoMode in any of these ways:

- In the embedded Web server (network model only), open the **Settings** tab and select the **PCL Settings** option.
- In the Windows printer driver, open the **Paper/Quality** tab and select the **EconoMode** option.
- In the Macintosh printer driver, open the **Print Quality** drop-down menu.

## Quiet mode

This product has a quiet mode that reduces noise during printing. When quiet mode is turned on, the product prints at a slower speed.

Follow these steps to enable quiet mode.

---

Windows	<ol style="list-style-type: none"><li>1. Open the printer-driver <b>Properties</b> screen, and then click the <b>Device Settings</b> tab. For instructions, see the third column of the table in <a href="#">Change printer-driver settings for Windows on page 14</a>.</li><li>2. In the <b>Quiet Mode</b> area, select <b>Enable</b>.</li></ol>
Macintosh	<ol style="list-style-type: none"><li>1. Open the HP Printer Utility. See <a href="#">Open the HP Printer Utility on page 19</a>.</li><li>2. Select <b>Set Quiet Mode</b>, and then select <b>On</b>.</li><li>3. Click the <b>OK</b> button.</li></ol>

---





---

## 8 Print tasks

- [Cancel a print job](#)
- [Use features in the Windows printer driver](#)

## Cancel a print job

You can stop a print request by using the control panel or by using the software program. For instructions about how to stop a print request from a computer on a network, see the online Help for the specific network software.

 **NOTE:** It can take some time for all printing to clear after you have canceled a print job.

---

### Stop the current print job from the control panel

▲ Press the Cancel button  on the control panel.

### Stop the current print job from the software program

When you send the print job, a dialog box appears briefly on the screen, giving you the option to cancel the print job.

If several requests have been sent to the product through your software, they might be waiting in a print queue (for example, in Windows Print Manager). See the software documentation for specific instructions about canceling a print request from the computer.

If a print job is waiting in a print queue or print spooler, delete the print job there.

1. **Windows XP and Windows Server 2003 (using the default Start menu view):** Click **Start**, click **Settings**, and then click **Printers and Faxes**.

-or-

**Windows 2000, Windows XP, and Windows Server 2003 (using the Classic Start menu view):** Click **Start**, click **Settings**, and then click **Printers**.

-or-

**Windows Vista:** Click **Start**, click **Control Panel**, and then in the category for **Hardware and Sound** click **Printer**.

2. In the list of printers, double-click the name of this product to open the print queue or spooler.
3. Select the print job that you want to cancel, and then press **Delete**.

# Use features in the Windows printer driver

## Open the printer driver

How do I	Steps to perform
Open the printer driver	On the <b>File</b> menu in the software program, click <b>Print</b> . Select the printer, and then click <b>Properties</b> or <b>Preferences</b> .
Get help for any printing option	Click the ? symbol in the upper-right corner of the printer driver, and then click any item in the printer driver. A pop-up message displays that provides information about the item. Or, click <b>Help</b> to open the online Help.

## Use Quick Sets

Quick Sets are available from every tab in the printer driver.

How do I	Steps to perform
Use a Quick Set	Select one of the Quick Sets, and then click <b>OK</b> to print the job with the predefined settings.
Create a custom Quick Set	a) Select the print options for the new Quick Set. b) Type a name for the Quick Set, and then click <b>Save</b> .

## Set paper and quality options

To perform the following tasks, open the printer driver and click the **Paper/Quality** tab.

How do I	Steps to perform
Select a page size	Select a size from the <b>Size is</b> drop-down list.
Select a custom page size	a) Click <b>Custom</b> . The <b>Custom Paper Size</b> dialog box opens. b) Type a name for the custom size, specify the dimensions, and click <b>OK</b> .
Select a paper source	Select a tray from the <b>Source is</b> drop-down list.
Select a paper type	Select a type from the <b>Type is</b> drop-down list.
Print covers on different paper	a) In the <b>Paper Options</b> area, click <b>Use Different Paper/Covers</b> . b) Select an option to print a blank or preprinted front cover, back cover, or both. Or, select an option to print the first or last page on different paper. c) Select options from the <b>Source is</b> and <b>Type is</b> drop-down lists. d) Click <b>OK</b> .
Print the first or last page on different paper	
Adjust the resolution of printed images	In the <b>Print Quality</b> area, select an option from the drop-down list. See the printer-driver online Help for information about each of the available options.
Select draft-quality printing	In the <b>Print Quality</b> area, click <b>EconoMode</b> .

## Set document effects

To perform the following tasks, open the printer driver and click the **Effects** tab.

How do I	Steps to perform
Scale a page to fit on a selected paper size	Click <b>Print document on</b> , and then select a size from the drop-down list.
Scale a page to be a percent of the actual size	Click <b>% of Normal Size</b> , and then type the percent or adjust the slider bar.
Print a watermark	a) Select a watermark from the <b>Watermarks</b> drop-down list. b) To print the watermark on the first page only, click <b>First page only</b> . Otherwise, the watermark is printed on each page.
Add or edit watermarks	a) In the <b>Watermarks</b> area, click <b>Edit</b> . The <b>Watermark Details</b> dialog box opens. b) Specify the settings for the watermark, and then click <b>OK</b> .

**NOTE:** The printer driver must be stored on your computer for this to work.

## Set document finishing options

To perform the following tasks, open the printer driver and click the **Finishing** tab.

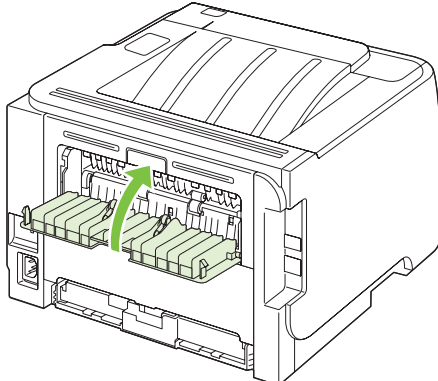
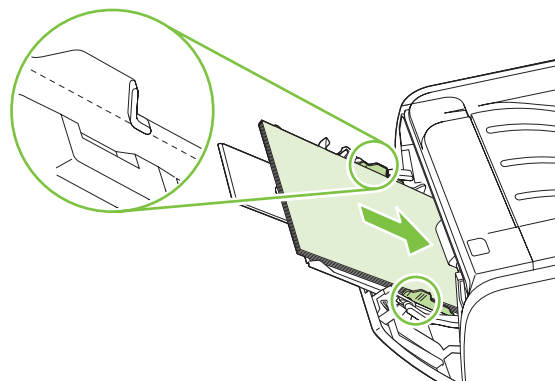
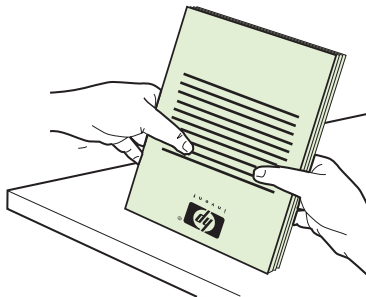
How do I	Steps to perform
Print on both sides (Duplex) using the top output bin	<ol style="list-style-type: none"><li data-bbox="861 325 1482 409">1. Click <b>Print On Both Sides (Manually)</b>. If you will bind the document along the top edge, click <b>Flip Pages Up</b>.</li><li data-bbox="861 409 1482 472">2. Close the straight-through output door.</li></ol>  <ol style="list-style-type: none"><li data-bbox="861 871 1482 913">3. Print side one of the document using Tray 1.</li></ol>  <ol style="list-style-type: none"><li data-bbox="861 1333 1482 1438">4. After side one has printed, remove the remaining paper from Tray 1 and set it aside until after you finish the manual two-sided print job.</li><li data-bbox="861 1438 1482 1501">5. Gather the printed pages and straighten the stack.</li></ol> 

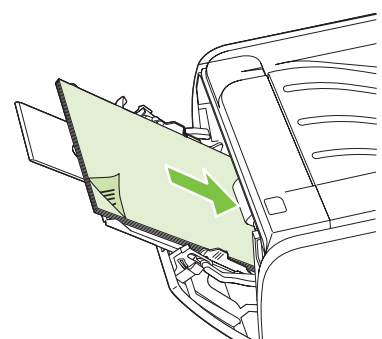
How do I	Steps to perform
	<p>6. Return the stack to Tray 1 with the printed side down and the top edge toward the product.</p>  <p>7. Press the <b>Go</b> button to print side two.</p>
Print a booklet	a) Click <b>Print on both sides</b> . b) In the <b>Booklet Printing</b> drop-down list, click <b>Left Edge Binding</b> or <b>Right Edge Binding</b> . The <b>Pages per Sheet</b> option automatically changes to <b>2 Pages per Sheet</b> .
Print multiple pages per sheet	a) Select the number of pages per sheet from the <b>Pages per Sheet</b> drop-down list. b) Select the correct options for <b>Print Page Borders</b> , <b>Page Order</b> , and <b>Orientation</b> .
Select page orientation	a) In the <b>Orientation</b> area, click <b>Portrait</b> or <b>Landscape</b> . b) To print the page image upside down, click <b>Rotate by 180 degrees</b> .

## Obtain support and product-status information

To perform the following tasks, open the printer driver and click the **Services** tab.

How do I	Steps to perform
Obtain support information for the product and order supplies online	In the <b>Internet Services</b> drop-down list, select a support option, and click <b>Go!</b>
Print information pages	In the <b>Print Information Pages</b> area, select one of the pages from the drop-down list, and then click the <b>Print</b> button.
Obtain information about product status lights	In the <b>Device Services</b> area, click the icon to open a control-panel light simulator. You can select a pattern of lights to find information about the product status.

## Set advanced printing options

To perform the following tasks, open the printer driver and click the **Advanced** tab.

How do I	Steps to perform
<p>Change the number of copies that are printed</p> <p><b>NOTE:</b> If the software program that you are using does not provide a way to print a particular number of copies, you can change the number of copies in the driver.</p> <p>Changing this setting affects the number of copies for all print jobs. After your job has printed, restore this setting to the original value.</p>	<p>In the <b>Copies</b> area, select the number of copies to print. If you select two or more copies, you can select the option to collate the pages.</p>
<p>Print colored text as black rather than as shades of gray</p>	<p>In the <b>Printer Features</b> area, select the <b>Print All Text as Black</b> option.</p>
<p>Use HP Resolution Enhancement technology (REt) for all print jobs</p>	<p>In the <b>Printer Features</b> area, select the <b>REt</b> option.</p>





---

## 9 Manage and maintain the product

- [Print the information pages](#)
- [Manage a network product](#)
- [Lock the product](#)
- [Manage supplies](#)
- [Replace supplies and parts](#)
- [Clean the product](#)

## Print the information pages

You can print the following information pages.

### Demo page

The Demo page contains examples of text and graphics. To print a Demo page, do one of the following:

- Press the **Go** button when the printer Ready light is on and no other jobs are printing.
- Select it from the **Print Information Pages** drop-down list on the **Services** tab in **Printer Preferences**.

### Configuration page

The Configuration page lists current settings and properties of the printer. It also contains a status log report. To print a configuration page, do one of the following:

- Press and hold the **Go** button for 5 seconds when the printer Ready light is on and no other jobs are printing.
- Select it from the **Print Information Pages** drop-down list on the **Services** tab in **Printer Preferences**.

### Supplies Status page

You can print the Supplies Status page by selecting it from the **Print Information Pages** drop-down list on the **Services** tab in **Printer Preferences**. The Supplies Status page provides the following information:

- The estimated number of pages remaining on the print cartridge
- The number of pages and print jobs that have been processed
- Ordering and recycling information

# Manage a network product

## Embedded Web server

The embedded Web server allows you to view product and network status and to manage printing functions from your computer. Use the embedded Web server for the following tasks:

- View product status information
- Determine the remaining life on all supplies and order new ones
- View and change the size and type of paper loaded in each tray
- View and change the product default configuration settings
- View and change network configuration

You do not need to install any software on the computer. Use one of these supported Web browsers:

- Internet Explorer 6.0 (and later)
- Netscape Navigator 7.0 (and later)
- Firefox 1.0 (and later)
- Mozilla 1.6 (and later)
- Opera 7.0 (and later)
- Safari 1.2 (and later)
- Konqueror 3.2 (and later)

The embedded Web server works when the product is connected to a TCP/IP-based network. The embedded Web server does not support IPX-based connections or direct USB connections.

---

 **NOTE:** You do not have to have Internet access to open and use the embedded Web server. However, if you click a link on any of the pages, you must have Internet access in order to go to the site associated with the link.

---

## Open the embedded Web server

To open the embedded Web server, type the IP address or hostname of the product in the address field of a supported Web browser.

---

 **TIP:** After you open the URL, bookmark it so that you can return to it quickly in the future.

---

The embedded Web server has three tabs that contain settings and information about the product: the **Information** tab, the **Settings** tab, and the **Networking** tab.

## Information tab

This tab provides information about product and supplies status, product and network configuration, and supplies reordering.

## Settings tab

This tab allows you to configure the product from your computer. If this product is networked, consult with the network administrator before changing settings on this tab.

## Networking tab

This tab allows the network administrator to control network-related settings for the product when it is connected to an IP-based network.

## Links

Links are located in the upper-right part of the Status pages. You must have Internet access in order to use any of these links. If you use a dial-up connection and did not connect when you first opened the embedded Web server, you must connect before you can visit these Web sites. Connecting might require that you close the embedded Web server and reopen it.

- **Order Supplies.** Click this link to connect to the Sure Supply Web site and order genuine HP supplies from HP or a reseller of your choice.
- **Product Support.** Click this link to connect to the support site for the product. You can search for help regarding general topics.

## Secure the embedded Web server

You can configure the embedded Web server so that access to some tabs requires a password.

See [Set or change the network password on page 27](#).

## Lock the product

The product has a slot that you can use to attach a cable-type security lock.

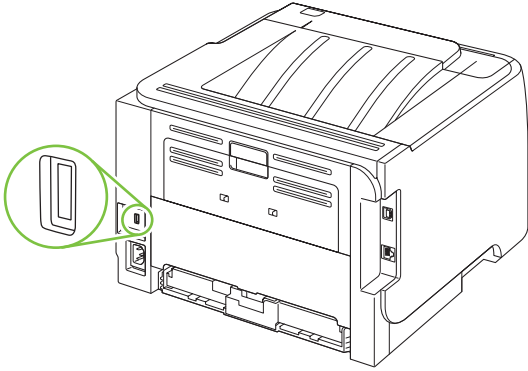

# Manage supplies

Using, storing, and monitoring the print cartridge can help ensure high-quality output.

## Supplies life

For information regarding specific product yield, see [www.hp.com/go/learnaboutsupplies.com](http://www.hp.com/go/learnaboutsupplies.com).

To order supplies, see [Supplies and accessories on page 107](#).

## Manage the print cartridge

### Print-cartridge storage

Do not remove the print cartridge from its package until you are ready to use it.

---

△ **CAUTION:** To prevent damage to the print cartridge, do not expose it to light for more than a few minutes.

---

### Use genuine HP print cartridges

When you use a genuine new HP print cartridge, you can obtain the following supplies information:

- Percentage of supplies remaining
- Estimated number of pages remaining
- Number of pages printed

### HP policy on non-HP print cartridges

Hewlett-Packard Company cannot recommend the use of non-HP print cartridges, either new or remanufactured.

---

📄 **NOTE:** Any damage caused by a non-HP print cartridge is not covered under the HP warranty and service agreements.

---

To install a new HP print cartridge, see [Change the print cartridge on page 63](#). To recycle the used cartridge, follow the instructions included with the new cartridge.

### Print-cartridge authentication

The device automatically authenticates the print cartridge when it is inserted into the device. During authentication, the device notifies you whether a cartridge is a genuine HP print cartridge.

If the alert message states that this is not a genuine HP print cartridge and you believe you purchased an HP print cartridge, see [HP fraud hotline and Web site on page 60](#).

### HP fraud hotline and Web site

Call the HP fraud hotline (1-877-219-3183, toll-free in North America) or go to [www.hp.com/go/anticounterfeit](http://www.hp.com/go/anticounterfeit) when you install an HP print cartridge and the control-panel message says the cartridge is non-HP. HP will help determine if the cartridge is genuine and take steps to resolve the problem.

Your print cartridge might not be a genuine HP print cartridge if you notice the following:

- You are experiencing a high number of problems with the print cartridge.
- The cartridge does not look like it usually does (for example, the orange pull tab is missing, or the packaging differs from HP packaging).

# Replace supplies and parts

## Supply replacement guidelines

Keep the following guidelines in mind when setting up the product.

- Sufficient space is required above and in the front of the product for removing supplies.
- The product should be located on a flat, sturdy surface.

 **NOTE:** Hewlett-Packard recommends the use of HP supplies in this product. Use of non-HP supplies can cause problems requiring service that is not covered by the HP warranty or service agreements.

## Redistribute toner

When toner is low, faded or light areas appear on the printed page. You might be able to temporarily improve print quality by redistributing the toner.

1. Push the button to open the print-cartridge door, and then remove the print cartridge.

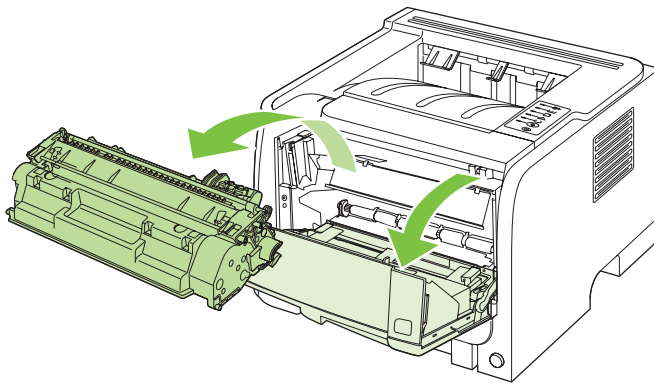

2. To redistribute the toner, gently rock the print cartridge from front to back.

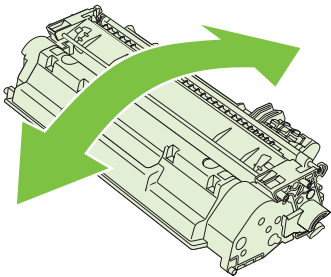

 **CAUTION:** If toner gets on your clothing, wipe it off with a dry cloth and wash the clothing in cold water. *Hot water sets toner into the fabric.*



3. Reinsert the print cartridge into the product, and then close the print-cartridge door.

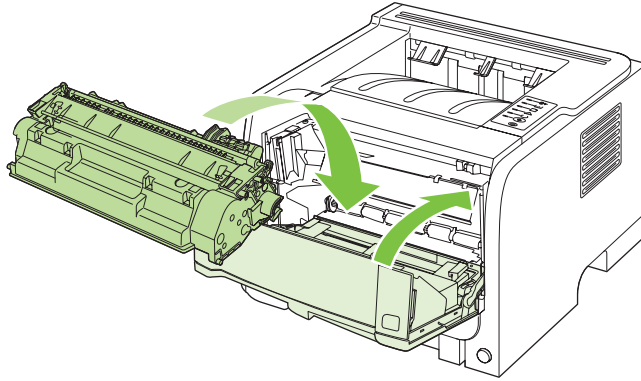

If the print is still light, install a new print cartridge.

## Change the print cartridge

When a print cartridge approaches the end of useful life, you are prompted to order a replacement. You can continue printing with the current cartridge until redistributing the toner no longer yields acceptable print quality.

1. Push the button to open the print-cartridge door, and then remove the print cartridge.

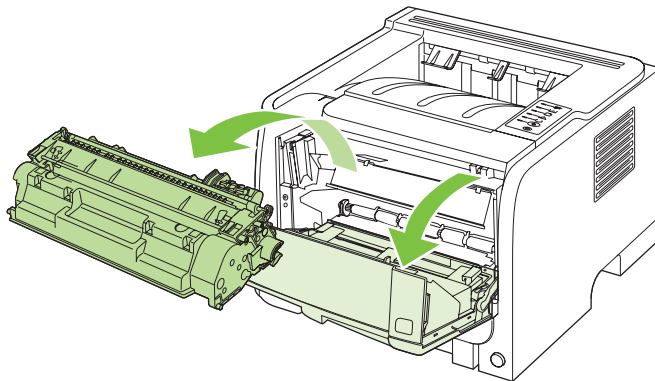

2. Remove the new print cartridge from the bag. Place the used print cartridge in the bag for recycling.

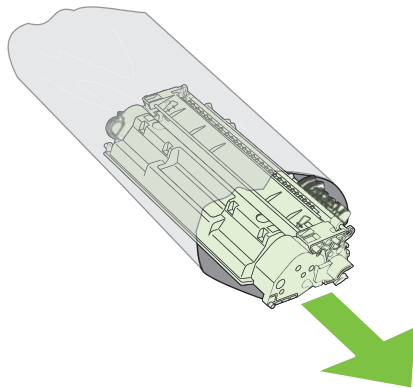

3. Grasp both sides of the print cartridge and distribute the toner by gently rocking the print cartridge.

△ **CAUTION:** Do not touch the shutter or the surface of the roller.

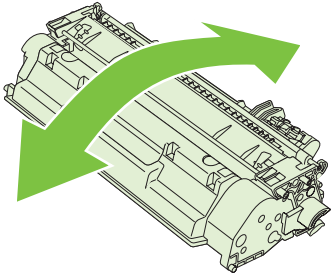

4. Bend the tab on the left side of the cartridge until the tab breaks loose. Pull the tab until all the tape is removed from the cartridge. Place the tab and tape in the print-cartridge box to return for recycling.

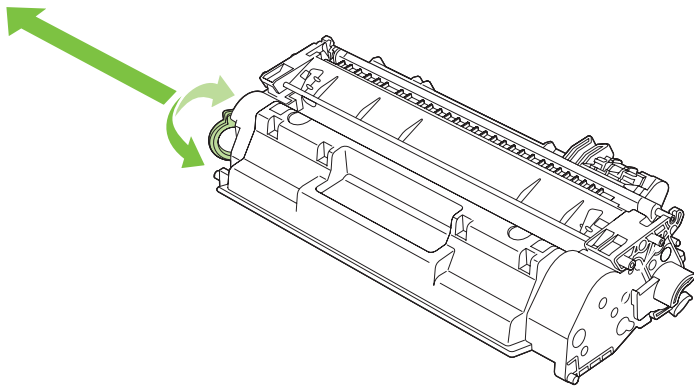

5. Align the print cartridge with the tracks inside the product, insert the print cartridge until it is firmly seated, and then close the print-cartridge door.

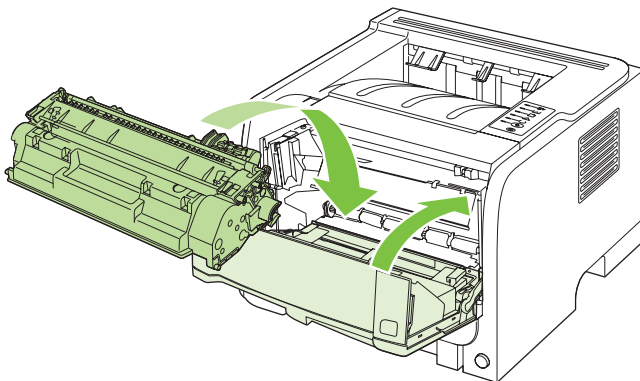

6. Installation is complete. Place the used print cartridge in the box in which the new cartridge arrived. See the enclosed recycling guide for recycling instructions.

For additional help, go to [www.hp.com/support/ljp2030series](http://www.hp.com/support/ljp2030series).

## Clean the product

Clean the outside of the printer with a clean, damp cloth when necessary.

- △ **CAUTION:** Do not use ammonia-based cleaners on or around the printer.
- 

During the printing process, paper, toner, and dust particles can accumulate inside the printer. Over time, this buildup can cause print quality problems, such as toner specks or smearing, and paper jams. To correct and prevent these types of problems, you can clean the print cartridge area and the printer media path.

### Clean the print-cartridge area

You do not need to clean the print-cartridge area often. However, cleaning this area can improve the quality of your printed sheets.

- △ **WARNING!** To avoid injury, turn the product off, disconnect the power cord, and wait for the product to cool before cleaning it.
- 

1. Open the print-cartridge door, and then remove the print cartridge.

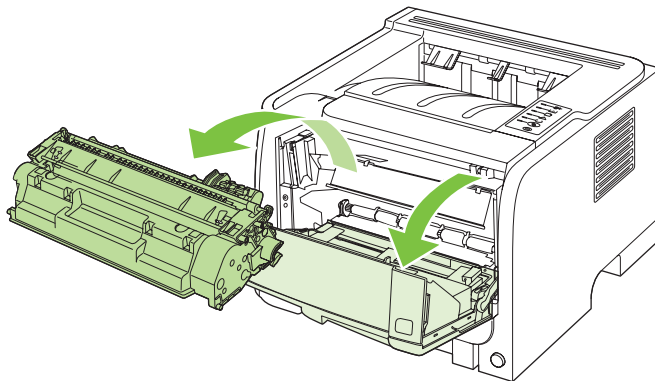

- △ **CAUTION:** Do not touch the black sponge-transfer roller inside the product. Doing so can damage the product.

**CAUTION:** To prevent damage, do not expose the print cartridge to light. Cover it with a piece of paper.

---

2. With a dry, lint-free cloth, wipe any residue from the media-path area and the print-cartridge cavity.

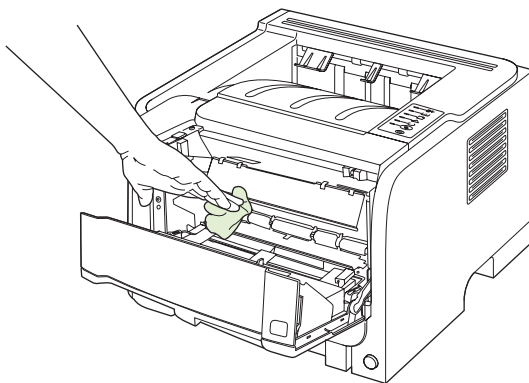

3. Replace the print cartridge, and close the print-cartridge door.

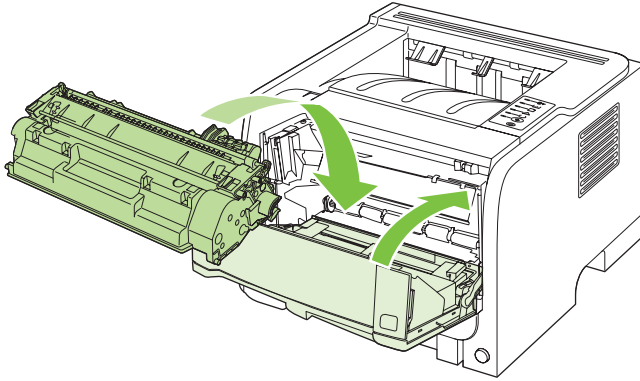

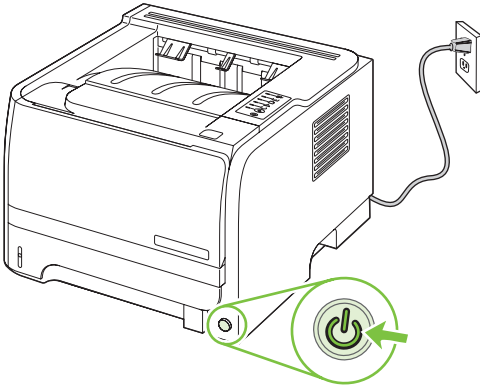

4. Reconnect the power cord, and turn the product on.

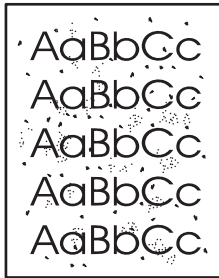

## Clean the paper path

If you are experiencing toner specks or dots on the printouts, clean the printer media path. This process uses a transparency to remove dust and toner from the media path. Do not use bond or rough paper.



 **NOTE:** For best results use a sheet of transparency. If you do not have any transparencies, you can use copier grade media (70 to 90 g/m<sup>2</sup> (18 to 24 lb)) with a smooth surface.

1. Make sure that the product is idle and the Ready light is on.
2. Load the transparency in Tray 1.
3. Print a cleaning page.

---

Windows

1. Open the printer-driver **Properties** screen, and then click the **Device Settings** tab. For instructions, see the third column of the table in [Change printer-driver settings for Windows on page 14](#).
2. In the **Cleaning Page** area, click **Start**.

---

Macintosh

1. Open the HP Printer Utility. See [Open the HP Printer Utility on page 19](#).
  2. Select the **Cleaning Page** option, and click the **OK** button.
- 

 **NOTE:** The cleaning process takes approximately 2 minutes. The cleaning page stops periodically during the cleaning process. Do not turn the product off until the cleaning process has finished. You might need to repeat the cleaning process several times to thoroughly clean the product.

## Clean the Tray 1 pickup roller

If the product is having trouble picking up paper from Tray 1, follow these instructions.

1. Turn the product off, disconnect the power cord, and wait for the product to cool.

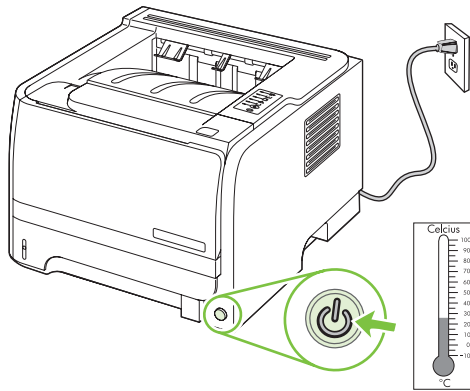

2. Push the button to open the print-cartridge door, and then remove the print cartridge.

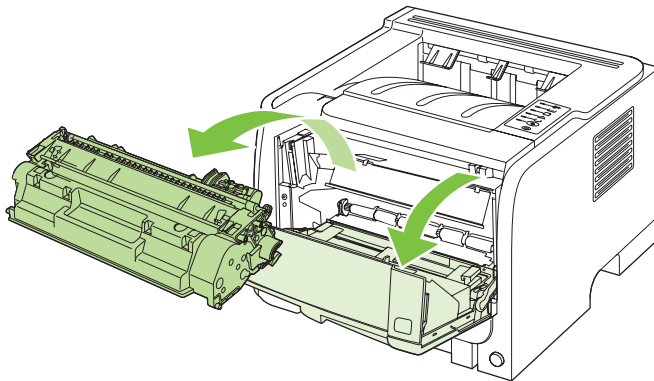

---

△ **CAUTION:** Do not touch the black sponge-transfer roller inside the product. Doing so can damage the product.

**CAUTION:** To prevent damage, do not expose the print cartridge to light. Cover it with a piece of paper.

---

3. Lift the pickup roller cover.

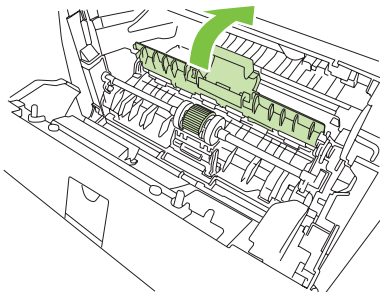

4. Press the two black retaining tabs outward until the pickup roller is released from its seat.

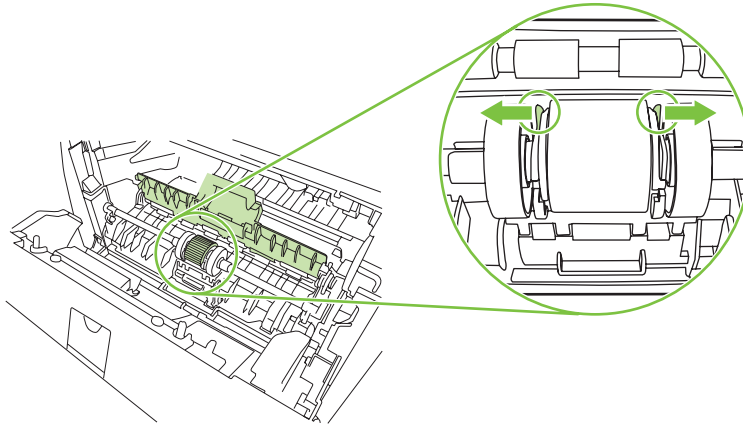

5. Remove the pickup roller from the product.

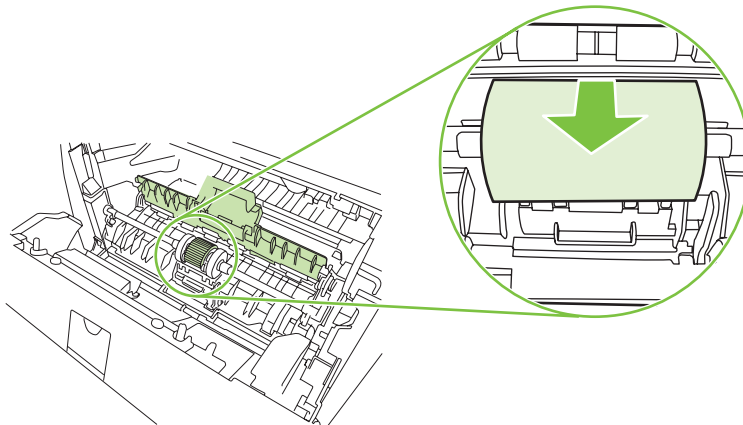

6. Dab a lint-free cloth in water, and scrub the roller.

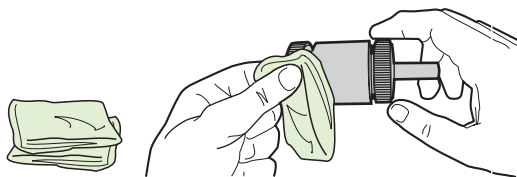

---

 **NOTE:** Do not touch the surface of the roller with bare fingers.

---

7. Using a dry, lint-free cloth, wipe the pickup roller to remove loosened dirt.

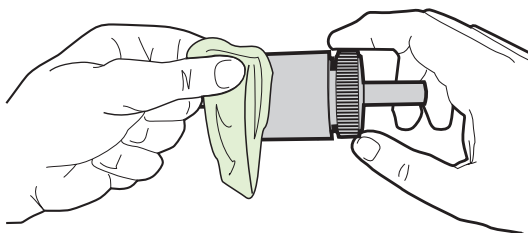

8. Allow the pickup roller to dry completely.

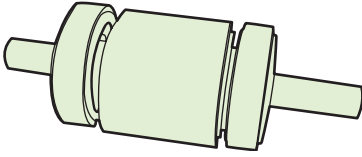

9. Line up the black retaining tabs in the product with the grooves in the pickup roller, and then press the pickup roller into the pickup roller seat until the retaining tabs click.

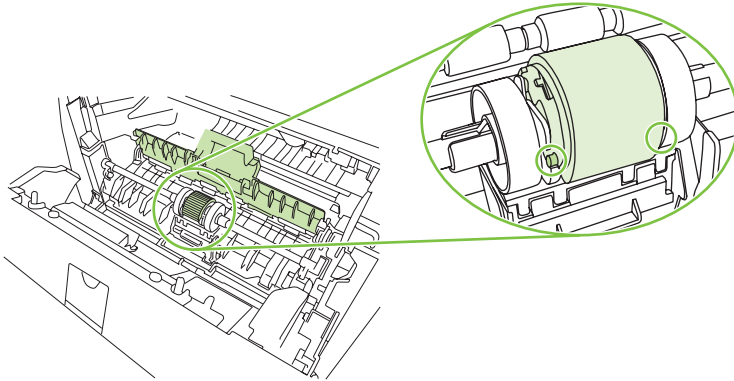

10. Close the pickup roller cover.

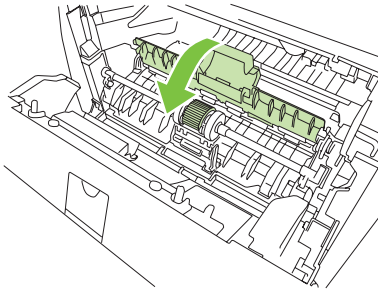

11. Reinstall the print cartridge, and close the print-cartridge door.

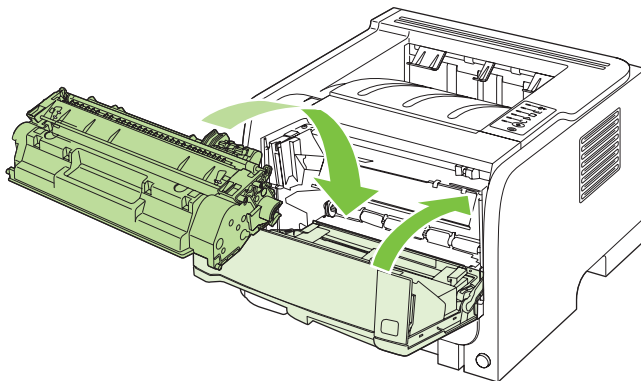



12. Reconnect the power cord, and turn the product on.

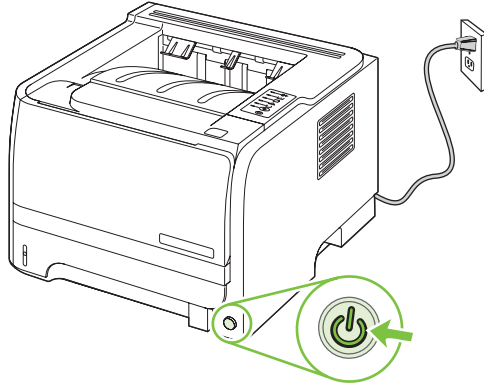

## Clean the Tray 2 pickup roller

If the product is having trouble picking up paper from Tray 2, follow these instructions.

1. Turn the product off, disconnect the power cord and wait for the product to cool.

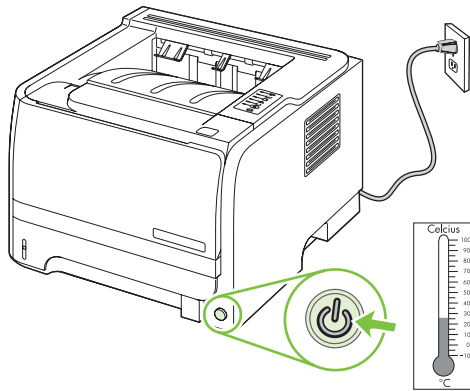

2. Remove Tray 2.

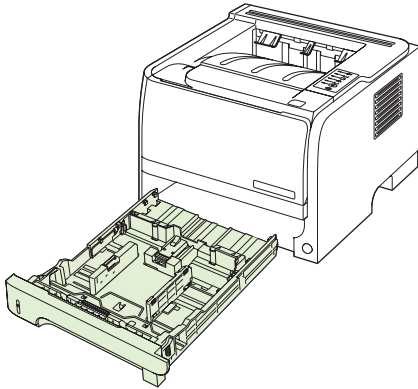

3. Inside the empty tray slot, locate the pickup roller on the top side, near the front of the product.

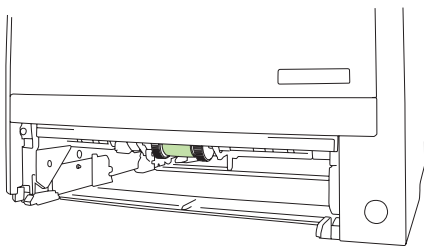

4. Dab a lint-free cloth in water, and then scrub the roller as you rotate it toward the back of the product.

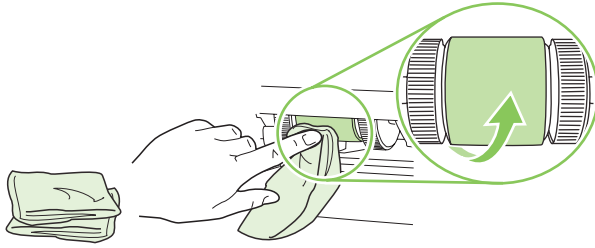

---

 **NOTE:** Do not touch the surface of the roller with bare fingers.

---

5. Using a dry, lint-free cloth, wipe the pickup roller to remove loosened dirt.

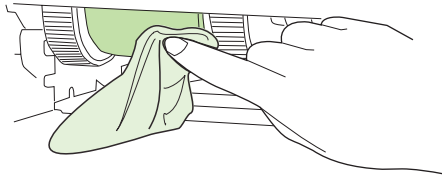

6. Allow the pickup roller to dry completely.

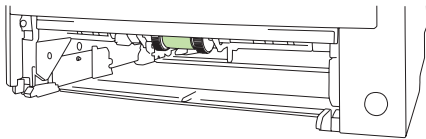

7. Replace Tray 2.

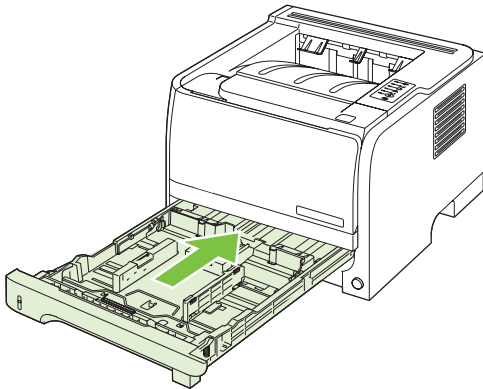

8. Reconnect the power cord, and turn the product on.

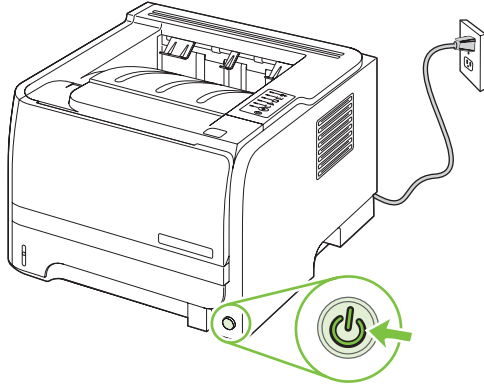

---

# 10 Solve problems

- [Solve general problems](#)
- [Restore factory settings](#)
- [Status-light patterns](#)
- [Status-alert messages](#)
- [Jams](#)
- [Solve print-quality problems](#)
- [Solve performance problems](#)
- [Solve connectivity problems](#)
- [Solve common Windows problems](#)
- [Solve common Macintosh problems](#)
- [Solve Linux problems](#)

## Solve general problems

If the product is not responding correctly, complete the steps in the following checklist, in order. If the product does not pass a step, follow the corresponding troubleshooting suggestions. If a step resolves the problem, you can stop without performing the other steps on the checklist.

### Troubleshooting checklist

1. Make sure the product Ready light is on. If no lights are on, complete these steps:
  - a. Check the power-cable connections.
  - b. Check that the power switch is on.
  - c. Make sure that the line voltage is correct for the product power configuration. (See the label that is on the back of the product for voltage requirements.) If you are using a power strip and its voltage is not within specifications, plug the product directly into the wall. If it is already plugged into the wall, try a different outlet.
  - d. If none of these measures restores power, contact HP Customer Care.
2. Check the cabling.
  - a. Check the cable connection between the product and the computer or network port. Make sure that the connection is secure.
  - b. Make sure that the cable itself is not faulty by using a different cable, if possible.
  - c. Check the network connection. See [Solve network problems on page 101](#).
3. Check to see any control-panel lights are lit. See [Status-light patterns on page 78](#).
4. Ensure that the paper that you are using meets specifications.
5. Print a configuration page. See [Print the information pages on page 56](#).
  - a. If the page does not print, check that at least one tray contains paper.
  - b. If the page jams in the product, see [Clear jams on page 87](#).
6. If the configuration page prints, check the following items.
  - a. If the page does not print correctly, the problem is with the product hardware. Contact HP Customer Care.
  - b. If the page prints correctly, then the product hardware is working. The problem is with the computer you are using, with the printer driver, or with the program.
7. Select one of the following options:

**Windows:** Click **Start**, click **Settings**, and then click **Printers**, or **Printers and Faxes**. Double-click the name of the product.

**-or-**

**Mac OS X:** Open **Print Center** or **Printer Setup Utility**, and double-click the line for the product.

8. Verify that you have installed the printer driver for this product. Check the program to make sure that you are using the printer driver for this product.
9. Print a short document from a different program that has worked in the past. If this solution works, then the problem is with the program you are using. If this solution does not work (the document does not print) complete these steps:
  - a. Try printing the job from another computer that has the product software installed.
  - b. If you connected the product to the network, connect the product directly to a computer with a USB cable. Redirect the product to the correct port, or reinstall the software, selecting the new connection type that you are using.

## Factors that affect product performance

Several factors affect the time it takes to print a job:

- Maximum product speed, measured in pages per minute (ppm)
- The use of special paper (such as transparencies, heavy paper, and custom-size paper)
- Product processing and download time
- The complexity and size of graphics
- The speed of the computer you are using
- The USB connection
- The printer I/O configuration
- The network operating system and configuration (if applicable)

## Restore factory settings

To restore the product to the factory-default settings, follow these steps.

1. Turn the product off.
2. Turn the product on, and while it is initializing press and hold both control-panel buttons at the same time until all the lights blink in unison.

# Status-light patterns

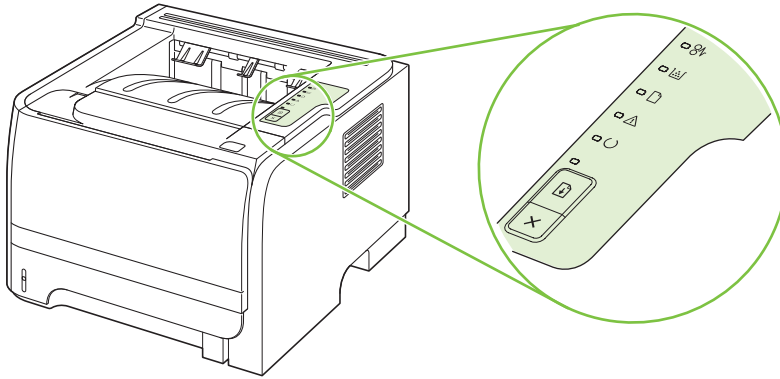

**Table 10-1 Status-light legend**

	Symbol for "light off"
	Symbol for "light on"
	Symbol for "light blinking"

**Table 10-2 Control-panel light messages**

Light status	State of the printer	Action
	<p><b>Initialization/Startup</b></p> <p>While in the Startup state, the Go, Ready, and Attention lights cycle (at the rate of 500 ms) one after another.</p>	<p>During the Initialization, Reconfiguration, and Job Cancel processes, pressing buttons has no effect.</p>
	<p><b>Reconfiguration Initialization</b></p> <p>During the printer start up, you can request special initialization sequences that reconfigure the printer. When one of the sequences is requested, such as cold reset, the lights cycle as in the Initialization/Startup state.</p>	
	<p><b>Job Cancel</b></p> <p>After the cancellation process has been completed, the printer returns to the Ready state.</p>	

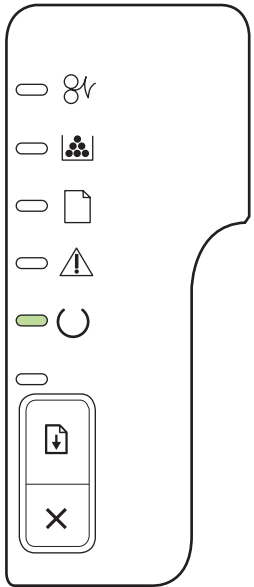
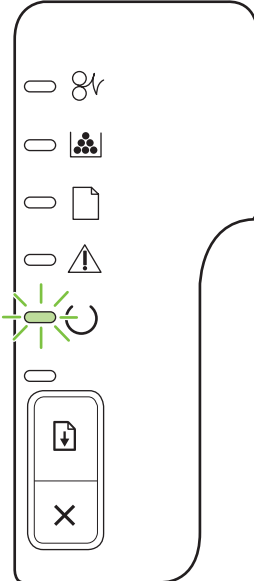

**Table 10-2 Control-panel light messages (continued)**

Light status	State of the printer	Action
	<p><b>Ready</b></p> <p>The printer is ready with no job activity.</p>	<p>To print a Configuration page, press and hold the <b>Go</b> button for 5 seconds while the device Ready light is on and no other jobs are printing.</p>
	<p><b>Processing Data</b></p> <p>The printer is processing or receiving data.</p>	<p>To cancel the current job, press the <b>Cancel</b> button.</p>

**Table 10-2 Control-panel light messages (continued)**

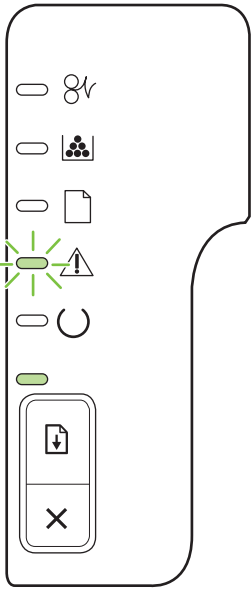
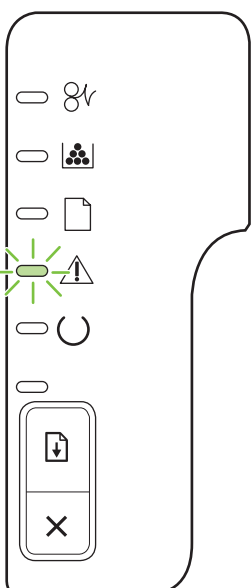
Light status	State of the printer	Action
	<p><b>Manual Feed or Continuable Error</b></p> <p>This state can be reached in the following circumstances:</p> <ul style="list-style-type: none"> <li>• Manual feed</li> <li>• General continuable error</li> <li>• Memory configuration error</li> <li>• Personality/Job related error</li> </ul>	<p>To recover from the error and print whatever data is possible, press the <b>Go</b> button.</p> <p>If the recovery is successful, the printer goes to the Processing Data state and completes the job.</p> <p>If the recovery is unsuccessful, the printer returns to the Continuable Error state.</p>
	<p><b>Attention</b></p> <p>The print-cartridge door is open.</p>	<p>Close the print-cartridge door.</p>

**Table 10-2 Control-panel light messages (continued)**

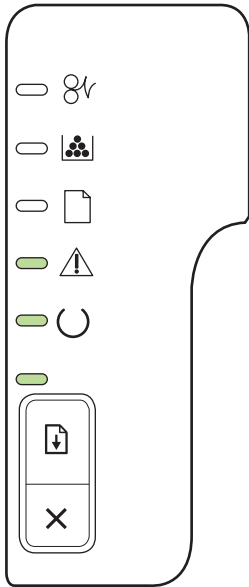
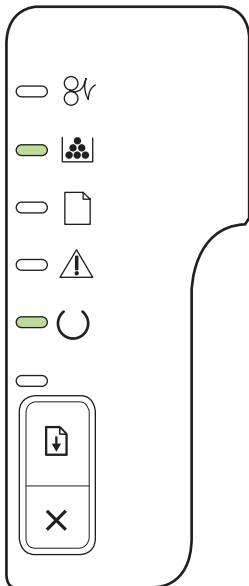
Light status	State of the printer	Action
	<p><b>Fatal Error</b></p>	<ul style="list-style-type: none"> <li>• Turn off the printer, wait 10 seconds, and turn on the printer.</li> <li>• If you are unable to resolve the problem, contact HP. See <a href="#">Customer support on page 117</a>.</li> </ul>
	<p><b>Toner Low</b></p> <p>The Go, Ready, and Attention lights act independently of the Toner Low state.</p>	<p>Order a new print cartridge and have it ready. See <a href="#">Supplies and accessories on page 107</a>.</p>

**Table 10-2 Control-panel light messages (continued)**

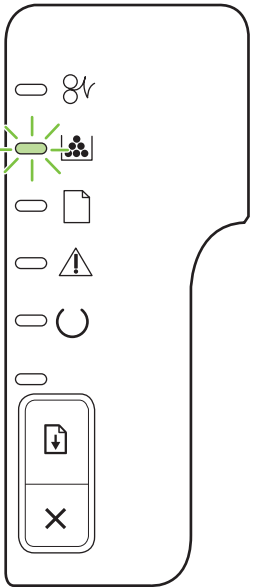
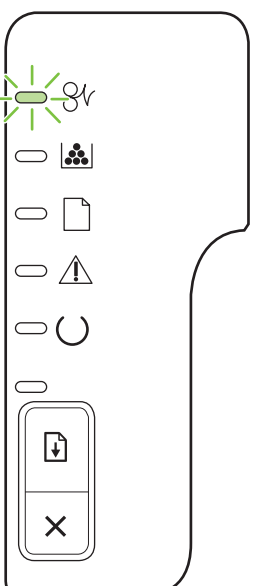
Light status	State of the printer	Action
	<p><b>Toner Missing</b></p> <p>The print cartridge has been removed from the printer.</p>	<p>Reinsert the print cartridge in the printer.</p>
	<p><b>Jam</b></p>	<p>Clear the jam. See <a href="#">Clear jams on page 87</a>.</p>

**Table 10-2 Control-panel light messages (continued)**

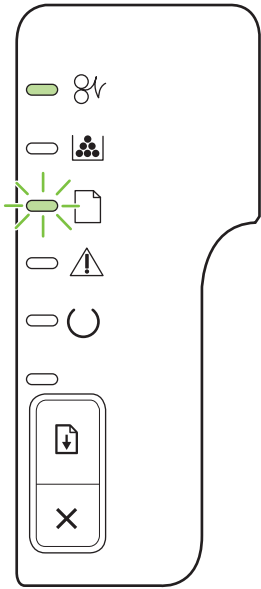
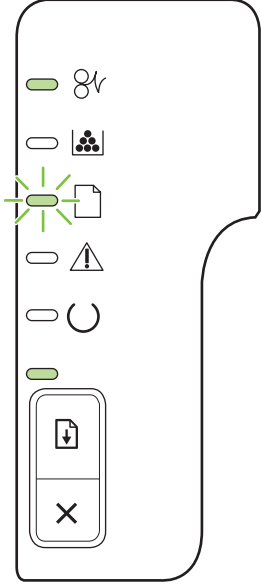
Light status	State of the printer	Action
	<b>Paper Out</b>	Load paper or other media.
	<b>Paper Mount</b> The loaded paper or other media is not supported.	Load acceptable paper or other media. See <a href="#">Paper and print media on page 29</a> . Press the <b>Go</b> button to override the condition.

## Status-alert messages

Status-alert messages appear on the computer screen when the product has certain problems. Use the information in the following table to solve these problems.

Alert message	Description	Recommended action
<b>10.XXXX Supply memory error</b>	The e-label for the print cartridge cannot be read or is missing.	<ul style="list-style-type: none"> <li>Reinstall the print cartridge.</li> <li>Turn the product off and then on.</li> <li>If the problem is not solved, replace the cartridge.</li> </ul>
<b>50.X Fuser error</b>	The product has experienced an error with the fuser.	<p>Turn off the power by using the power switch, wait at least 30 seconds, and then turn on the power and wait for the product to initialize.</p> <p>If the error continues, turn off the product, wait at least 25 minutes, and then turn on the product.</p> <p>If you are using a surge protector, remove it. Plug the product directly into the wall socket. Use the power switch to turn on the product.</p> <p>If the message persists, contact HP support. See <a href="#">Customer support on page 117</a>.</p>
<b>52.0 Scanner Error</b>	An internal error has occurred.	<p>Turn off the power by using the power switch, wait at least 30 seconds, and then turn on the power and wait for the product to initialize.</p> <p>If you are using a surge protector, remove it. Plug the product directly into the wall socket. Use the power switch to turn on the product.</p> <p>If the message persists, contact HP support. See <a href="#">Customer support on page 117</a>.</p>
<b>Door Open</b>	The door is open.	Close the door.
<b>Engine communication error</b>	The product experienced an internal communication error.	<p>Turn off the power by using the power switch, wait at least 30 seconds, and then turn on the power and wait for the product to initialize.</p> <p>If you are using a surge protector, remove it. Plug the product directly into the wall socket. Use the power switch to turn on the product.</p> <p>If the message persists, contact HP support. See <a href="#">Customer support on page 117</a>.</p>
<b>Install black cartridge</b>	The cartridge is either not installed or not correctly installed in the product.	Install the print cartridge.
<b>Jam in &lt;location&gt;</b> (<location> indicates the area where the jam has occurred)	The product has detected a jam.	<p>Clear the jam from the area indicated in the message. The job should continue to print. If it does not, try reprinting the job. See <a href="#">Jams on page 86</a>.</p> <p>If the message persists, contact HP support. See <a href="#">Customer support on page 117</a>.</p>
<b>Load paper</b>	The tray is empty.	Load print media into the tray.

Alert message	Description	Recommended action
<b>Manual feed</b>	The product is set for manual feed mode.	Load the correct paper into the tray, and then press the <b>Go</b> button to clear the message.
<b>Non-HP black cartridge</b>	A new, non-HP supply has been installed. This message appears until an HP supply is installed or you press the <b>Go</b> button.	<p>If you believe you purchased an HP supply, go to <a href="http://www.hp.com/go/anticounterfeit">www.hp.com/go/anticounterfeit</a>.</p> <p>Service or repairs that are required as a result of using non-HP supplies are not covered under HP warranty.</p> <p>To continue printing, press the <b>Go</b> button.</p>
<b>Not Connected</b>	The product software cannot communicate with the product.	<ol style="list-style-type: none"> <li>1. Make sure the product is turned on.</li> <li>2. Make sure the USB cable is connected securely to the product and the computer.</li> </ol>
<b>Order black cartridge</b>	The identified print cartridge is nearing the end of its useful life.	Order a new print cartridge. You can continue printing with the current print cartridge until redistributing the toner no longer yields acceptable print quality.
<b>Page too complex</b>	The product cannot process the page.	Press the <b>Go</b> button to continue printing the job, but output might be affected.
<b>Printer mispick</b>	The print engine has failed to pick up a piece of paper.	<p>Reload the paper in the input tray and press the <b>Go</b> button to continue the job.</p> <p>If the message persists, contact HP support. See <a href="#">Customer support on page 117</a>.</p>
<b>Printing</b>	The product is printing a document.	Wait for printing to finish.

# Jams

## Common causes of jams

Many jams are caused by using paper that does not meet HP specifications. For complete paper specifications for all HP LaserJet products, see the *HP LaserJet Printer Family Print Media Guide*. This guide is available at [www.hp.com/support/ljpaperguide](http://www.hp.com/support/ljpaperguide).

### The product is jammed.<sup>1</sup>

Cause	Solution
The paper does not meet specifications.	Use only paper that meets HP specifications. See <a href="#">Paper and print media on page 29</a> .
A component is installed incorrectly.	Verify that the print cartridge is correctly installed.
You are using paper that has already passed through a product or copier.	Do not use paper that has been previously printed on or copied.
A tray is loaded incorrectly.	Remove any excess paper from the tray. Make sure that the stack is below the maximum stack height mark in the tray. See <a href="#">Load trays on page 36</a> .
The paper is skewed.	The tray guides are not adjusted correctly. Adjust them so they hold the stack firmly in place without bending it.
The paper is binding or sticking together.	Remove the paper, flex it, rotate it 180°, or flip it over. Reload the paper into the tray.  <b>NOTE:</b> Do not fan paper. Fanning can create static electricity, which can cause paper to stick together.
The paper is removed before it settles into the output bin.	Reset the product. Wait until the page completely settles in the output bin before removing it.
During two-sided printing, you removed the paper before the second side of the document was printed.	Reset the product and print the document again. Wait until the page completely settles in the output bin before removing it.
The paper is in poor condition.	Replace the paper.
The internal rollers from the tray are not picking up the paper.	Remove the top sheet of paper. If the paper is too heavy, it might not be picked from the tray.
The paper has rough or jagged edges.	Replace the paper.
The paper is perforated or embossed.	Perforated or embossed paper does not separate easily. Feed single sheets from Tray 1.
Product supply items have reached the end of their useful life.	Check the product control panel for messages prompting you to replace supplies, or print a supplies status page to verify the remaining life of the supplies. See <a href="#">Print the information pages on page 56</a> .
Paper was not stored correctly.	Replace the paper in the trays. Paper should be stored in the original packaging in a controlled environment.

<sup>1</sup> If the product continues to jam, contact HP Customer Support or your authorized HP service provider.



## Jam locations

Jams can occur at the following locations in the product.

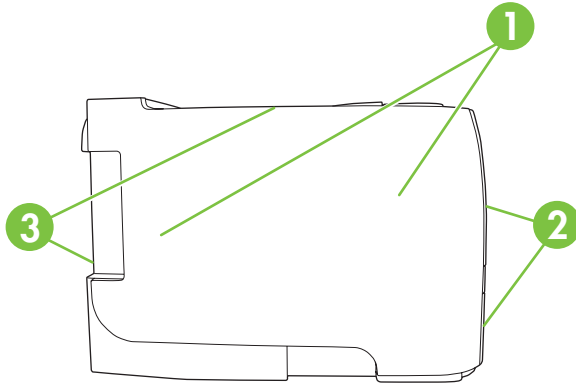

1	Internal areas
2	Input trays
3	Output bins

## Clear jams

When clearing jams, be careful not to tear jammed paper. If a small piece of paper remains in the product, it could cause additional jams.

△ **CAUTION:** Before clearing jams, turn the product off and disconnect the power cord.

### Internal areas

#### Print-cartridge area and paper path

1. Push the button to open the print-cartridge door, and then remove the print cartridge.

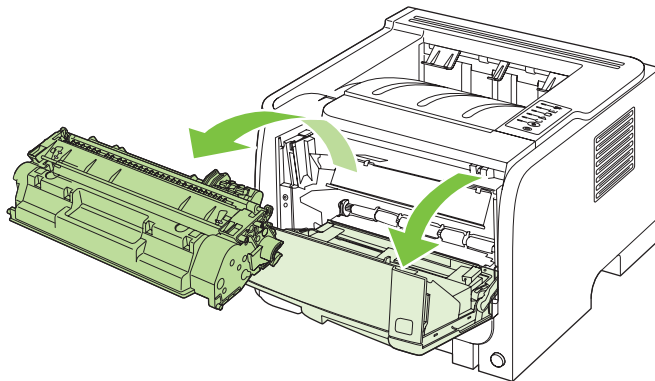

△ **CAUTION:** To prevent damage, do not expose the print cartridge to light. Cover it with a piece of paper.

2. If jammed paper is visible, grasp it with both hands and slowly pull it out of the product.

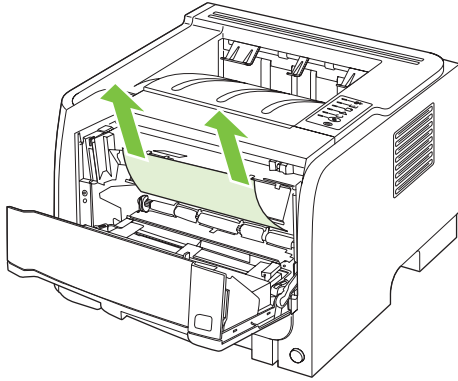

3. Replace the print-cartridge, and close the print-cartridge door.

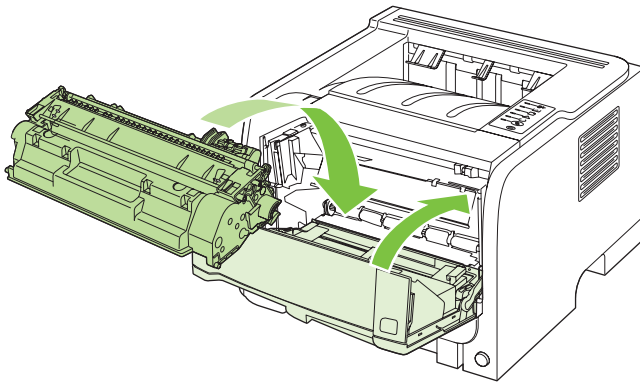

4. If no paper was jammed inside the print-cartridge door, open the jam-release door at the back of the product.

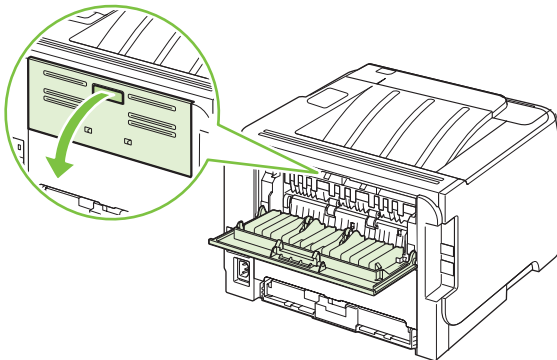

5. If jammed paper is visible, grasp it with both hands and slowly pull it out of the product.

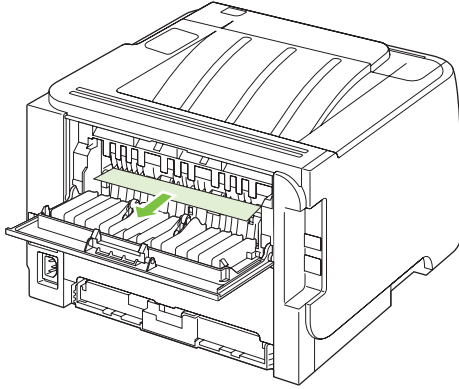

6. Close the jam-release door.

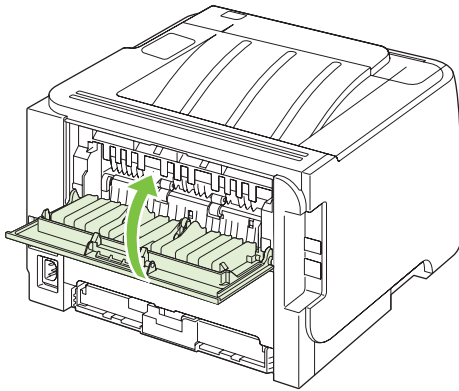

## Input trays

### Tray 1

1. Push the button to open the print-cartridge door, and then remove the print cartridge.

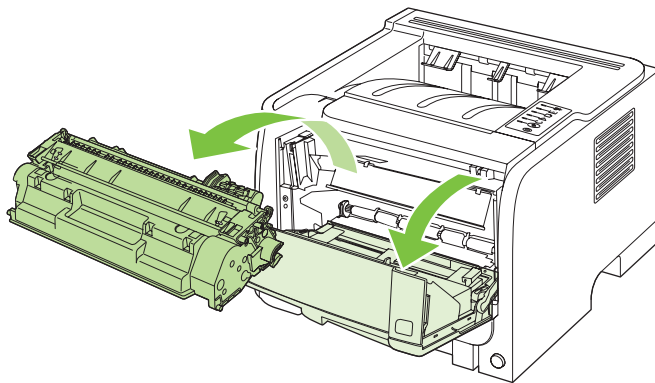

△ **CAUTION:** To prevent damage, do not expose the print cartridge to light. Cover it with a piece of paper.

2. Lift the Tray 1 roller cover, grasp the jammed paper, and slowly pull it out of the product.

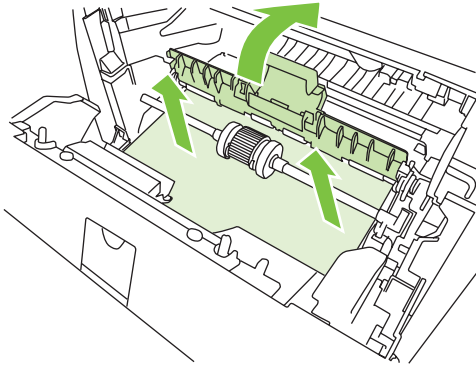

3. Replace the print-cartridge, and close the print-cartridge door.

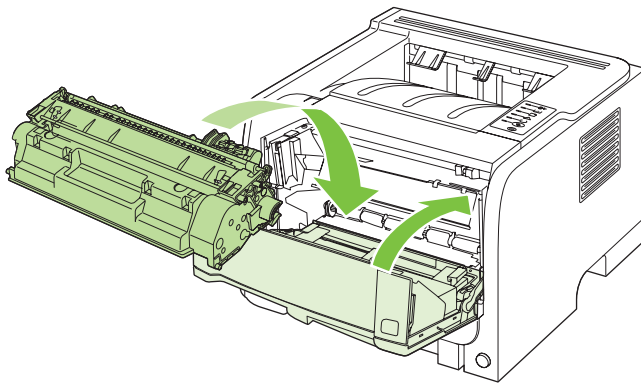

## Tray 2

1. Open the tray.

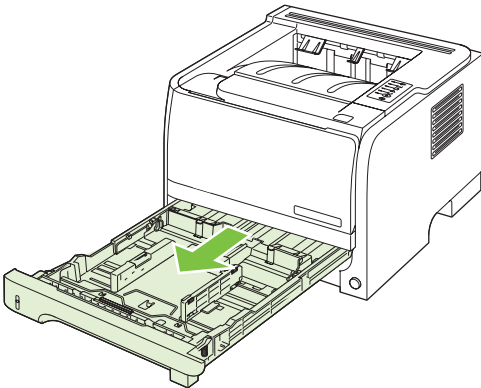

2. With both hands, grasp the jammed paper and slowly pull it out of the product.

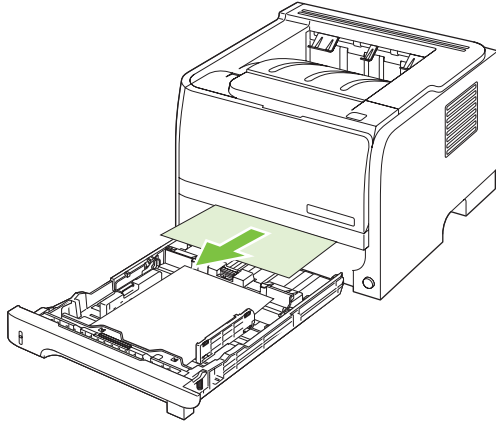

3. Close the tray.

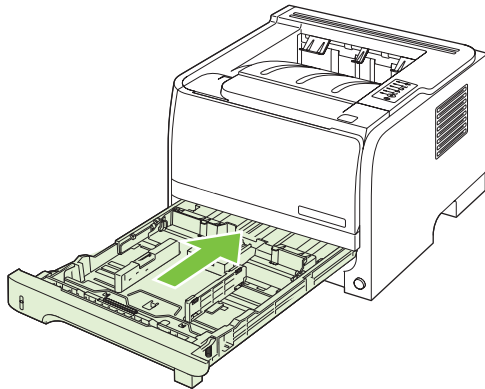

4. If no jammed paper is visible in the tray area, open the print-cartridge door, remove the print cartridge, and pull down the upper media guide. With both hands, grasp the jammed paper and slowly pull it out of the product.

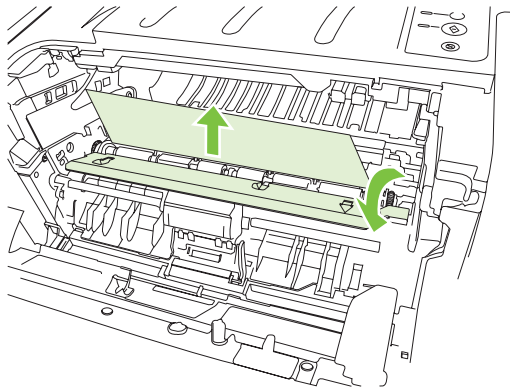

5. Replace the print-cartridge, and close the print-cartridge door.

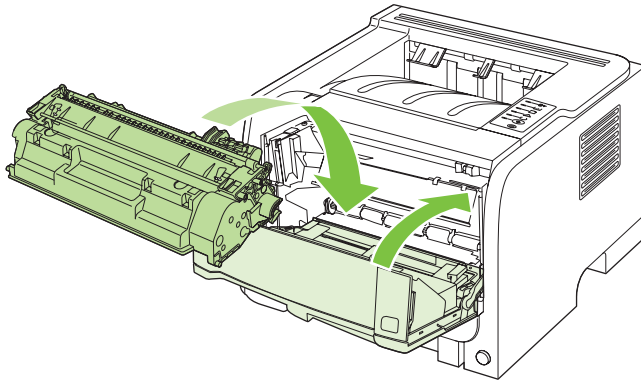

## Output bins

△ **CAUTION:** To avoid damaging the product, do not attempt to clear a jam in the top output bin by pulling the paper straight out.

1. At the back of the product, open the jam-release door.

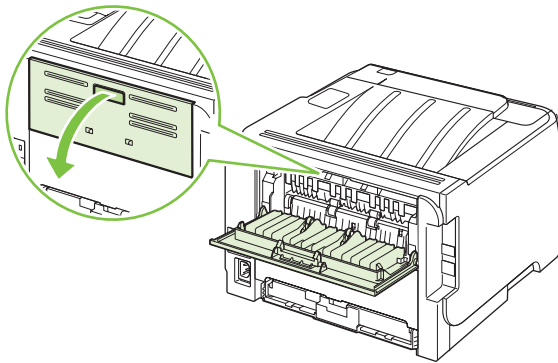

2. With both hands, grasp the jammed paper and slowly pull it out of the product.

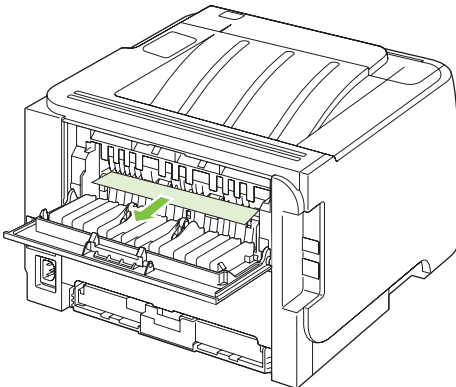

3. Close the jam-release door.

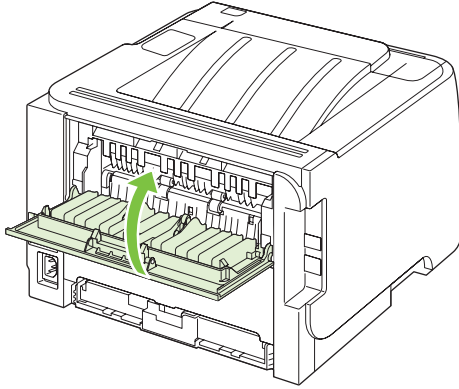

## Solve print-quality problems

You can prevent most print-quality problems by following these guidelines.

- Configure the trays for the correct paper-type setting. See [Configure trays on page 39](#).
- Use paper that meets HP specifications. See [Paper and print media on page 29](#).
- Clean the product as necessary. See [Clean the paper path on page 67](#).

### Print-quality problems associated with paper

Some print-quality problems arise from using paper that does not meet HP specifications.

- The surface of the paper is too smooth.
- The moisture content of the paper is uneven, too high, or too low. Use paper from a different source or from an unopened ream.
- Some areas of the paper reject toner. Use paper from a different source or from an unopened ream.
- The letterhead you are using is printed on rough paper. Use a smoother, xerographic paper. If this solves your problem, ask the supplier of your letterhead to use paper that meets HP specifications.
- The paper is excessively rough. Use a smoother, xerographic paper.
- The paper is too heavy for the paper-type setting that you selected, so the toner is not fusing to the paper.

For complete paper specifications for all HP LaserJet products, see the *HP LaserJet Printer Family Print Media Guide*. This guide is available at [www.hp.com/support/ljpaperguide](http://www.hp.com/support/ljpaperguide).

### Print-quality problems associated with the environment

If the product is operating in excessively humid or dry conditions, verify that the printing environment is within specifications. See [Operating environment on page 120](#).

### Print-quality problems associated with jams

Make sure that all sheets are cleared from the paper path.

- If the product recently jammed, print two to three pages to clean the paper path.
- If the sheets do not pass through the fuser and cause image defects on subsequent documents, print two to three pages to clean the paper path. If the problem persists, print and process a cleaning page. See [Clean the paper path on page 67](#).



## Adjust print density

You can resolve some print-quality problems by adjusting the print density to make the overall printing lighter or darker.

---

Windows	<ol style="list-style-type: none"><li>1. Open the printer-driver <b>Properties</b> screen, and then click the <b>Device Settings</b> tab. For instructions, see the third column of the table in <a href="#">Change printer-driver settings for Windows on page 14</a>.</li><li>2. In the <b>Print Density</b> area, adjust the slider bar to change the print density.</li><li>3. Click the <b>OK</b> button.</li></ol>
Macintosh	<ol style="list-style-type: none"><li>1. On the <b>File</b> menu, click <b>Print</b>.</li><li>2. Open the <b>Print Options</b> menu.</li><li>3. In the <b>Print Density</b> area, adjust the slider bar to change the print density.</li></ol>

---

## Image defect examples

This section provides information about identifying and correcting print defects.

 **NOTE:** If these steps do not correct the problem, contact an HP-authorized dealer or service representative.

### Light print or faded

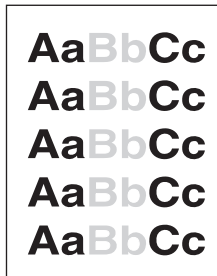

- The print cartridge is nearing end of life.
- Redistribute the toner to extend the life.
- The media might not meet Hewlett-Packard's media specifications (for example, the media is too moist or too rough).
- If the whole page is light, the print density adjustment is too light or EconoMode might be turned on. Adjust the print density, and disable EconoMode in the printer Properties.

### Toner specks

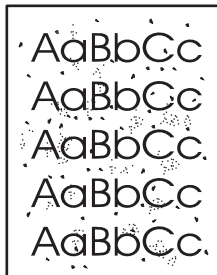

- The media might not meet Hewlett-Packard's media specifications (for example, the media is too moist or too rough).
- The printer might need to be cleaned.
- The print cartridge might be defective.

### Dropouts

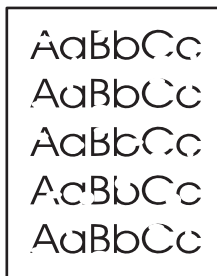

- A single sheet of media might be defective. Try reprinting the job.
- The media moisture content is uneven or the media has moist spots on its surface. Try printing with new media.
- The media lot is bad. The manufacturing processes can cause some areas to reject toner. Try a different type or brand of media.
- The print cartridge might be defective.

## Vertical lines

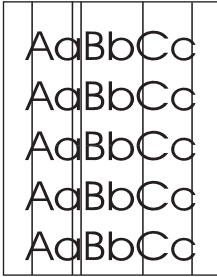

The photosensitive drum inside the print cartridge has probably been scratched. Install a new HP print cartridge.

## Gray background

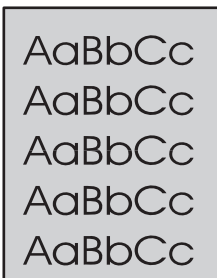

- Change the media to a lighter basis weight.
- Check the printer's environment. Very dry (low humidity) conditions can increase the amount of background shading.
- The density setting might be too high. Adjust the density setting.
- Install a new HP print cartridge.

## Toner smear



- If toner smears appear on the leading edge of the media, the media guides might be dirty. Wipe the media guides with a dry, lint-free cloth.
- Check the media type and quality.
- The fuser temperature might be too low. In your printer driver, make sure the appropriate media type is selected.
- Try installing a new HP print cartridge.

## Loose toner

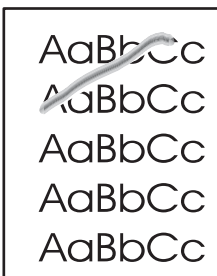

- The fuser temperature might be too low. In your printer driver, make sure the appropriate media type is selected.
- Clean the inside of the printer.
- Check the media type and quality.
- In your printer driver, make sure the appropriate media type is selected.
- Plug the printer directly into an AC outlet instead of into a power strip.

## Vertical repetitive defects



- The print cartridge might be damaged. If a repetitive mark occurs at the same spot on the page, install a new HP print cartridge.
- The internal parts might have toner on them. If the defects occur on the back of the page, the problem will probably correct itself after a few more printed pages.
- In your printer driver, make sure the appropriate media type is selected.

## Misformed characters

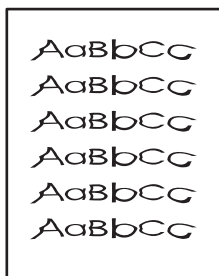

- If characters are improperly formed, producing hollow images, the media stock might be too slick. Try a different media.
- If characters are improperly formed, producing a wavy effect, the printer might need service. Print a configuration page. If the characters are improperly formed, contact an HP-authorized dealer or service representative.

## Page skew

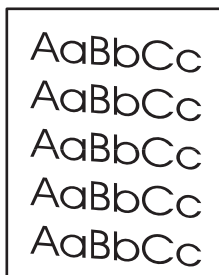

- Make sure that the media is loaded correctly and the media guides are not too tight or too loose against the media stack.
- The input bin might be too full.
- Check the media type and quality.

## Curl or wave

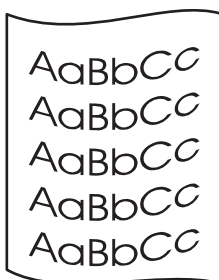

- Check the media type and quality. Both high temperature and high humidity cause media to curl.
- The media might have been in the input tray too long. Turn over the stack of media in the tray. Also, try rotating the media 180° in the input tray.
- Open the straight-through output door and try printing straight through.
- The fuser temperature might be too high. In your printer driver, make sure the appropriate media type is selected. If the problem persists, select a media type that uses a

---

lower fuser temperature, such as transparencies or light media.

---

## Wrinkles or creases

---

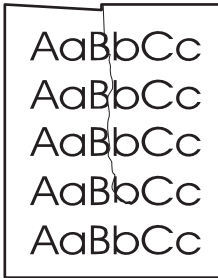

- Make sure that media is loaded properly.
  - Check the media type and quality.
  - Open the straight-through output door and try printing straight through.
  - Turn over the stack of media in the tray. Also, try rotating the media 180° in the input tray.
  - For envelopes, this can be caused by air pockets inside the envelope. Remove the envelope, flatten the envelope, and try printing again.
- 

## Toner scatter outline

---

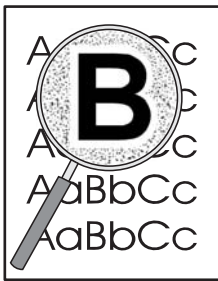

- If large amounts of toner have scattered around the characters, the media might be resisting the toner. (A small amount of toner scatter is normal for laser printing.) Try a different media type.
  - Turn over the stack of media in the tray.
  - Use media that is designed for laser printers.
-

# Solve performance problems

Problem	Cause	Solution
Pages print but are totally blank.	The sealing tape might still be in the print cartridges.	Verify that the sealing tape has been completely removed from the print cartridges.
	The document might contain blank pages.	Check the document that you are printing to see if content appears on all of the pages.
	The product might be malfunctioning.	To check the product, print a Configuration page.
Pages print very slowly.	Heavier paper types can slow the print job.	Print on a different type of paper.
	Complex pages can print slowly.	Proper fusing may require a slower print speed to ensure the best print quality.
Pages did not print.	The product might not be pulling paper correctly.	Make sure paper is loaded in the tray correctly.
	The paper is jamming in the product.	Clear the jam. See <a href="#">Jams on page 86</a> .
	The USB cable might be defective or incorrectly connected.	<ul style="list-style-type: none"><li>● Disconnect the USB cable at both ends and reconnect it.</li><li>● Try printing a job that has printed in the past.</li><li>● Try using a different USB cable.</li></ul>
	Other devices are running on your computer.	The product might not share a USB port. If you have an external hard drive or network switchbox that is connected to the same port as the product, the other device might be interfering. To connect and use the product, you must disconnect the other device or you must use two USB ports on the computer.

# Solve connectivity problems

## Solve direct-connect problems

If you have connected the product directly to a computer, check the cable.

- Verify that the cable is connected to the computer and to the product.
- Verify that the cable is not longer than 2 meters (6 feet). Replace the cable if necessary.
- Verify that the cable is working correctly by connecting it to another product. Replace the cable if necessary.

## Solve network problems

Check the following items to verify that the product is communicating with the network. Before beginning, print a configuration page. See [Print the information pages on page 56](#).

1. Are there any physical connection problems between the workstation or file server and the product?

Verify that the network cabling, connections, and router configurations are correct. Verify that the network cable lengths meet network specifications.

2. Are your network cables connected properly?

Make sure that the product is attached to the network using the appropriate port and cable. Check each cable connection to make sure it is secure and in the right place. If the problem continues, try a different cable or ports on the hub or transceiver. The amber activity light and the green link status light next to the port connection on the back of the product should be lit.

3. Are the link speed and duplex settings set correctly?

Hewlett-Packard recommends leaving this setting in automatic mode (the default setting). See [Link speed setting on page 27](#).

4. Can you "ping" the product?

Use the command prompt to ping the product from your computer. For example:

```
ping 192.168.45.39
```

Ensure that the ping displays round-trip times.

If you are able to ping the product, verify that the IP address configuration for the product is correct on the computer. If it is correct, delete and then add the product again.

If the ping command failed, verify that the network hubs are on, and then verify that the network settings, the product, and the computer are all configured for the same network.

5. Have any software applications been added to the network?

Make sure they are compatible and that they are installed correctly with the correct printer drivers.

6. Are other users able to print?

The problem may be workstation-specific. Check the workstation network drivers, printer drivers, and redirection (capture in Novell NetWare).

7. If other users are able to print, are they using the same network operating system?

Check your system for proper network operating system setup.

**8.** Is your protocol enabled?

Check the status of your protocol on the Configuration page. You can also use the embedded Web server to check the status of other protocols. See [Embedded Web server on page 57](#).

**9.** Does the product appear in HP Web Jetadmin or other management application?

- Verify network settings on the Network configuration page.
- Confirm the network settings for the product using the product control panel (for products with control panels).



# Solve common Windows problems

Error message:

"General Protection FaultException OE"

"Spool32"

"Illegal Operation"

---

Cause	Solution
	Close all software programs, restart Windows, and try again.
	Select a different printer driver. You can usually do this from a software program.
	Delete all temp files from the Temp subdirectory. You can determine the name of the directory by editing the AUTOEXEC.BAT file and looking for the statement "Set Temp =". The name after this statement is the temp directory. It is usually C:\TEMP by default, but can be redefined.
	See the Microsoft Windows documentation that came with your computer for more information about Windows error messages.

---

# Solve common Macintosh problems

 **NOTE:** Setup for USB and IP printing is performed through the Desktop Printer Utility. The product will *not* appear in the Chooser.

## The printer driver is not listed in Print Center.

Cause	Solution
The product software might not have been installed or was installed incorrectly.	Make sure that the PPD file is in the following hard drive folder: <code>Library/Printers/PPDs/Contents/Resources/&lt;lang&gt;.lproj</code> , where “<lang>” represents the two-letter language code for the language that you are using. If necessary, reinstall the software. See the getting started guide for instructions.

## The product name, IP address, or Rendezvous host name does not appear in the printer list box in the print center.

Cause	Solution
The product might not be ready.	Make sure that the cables are connected correctly, the product is on, and the ready light is on. If you are connecting through a USB or Ethernet hub, try connecting directly to the computer or use a different port.
The wrong connection type might be selected.	Make sure that USB, IP Printing, or Rendezvous is selected, depending on the type of connection that exists between the product and the computer.
The wrong product name, IP address, or Rendezvous host name is being used.	Check the product name, IP address, or Rendezvous host name by printing a configuration page. See <a href="#">Print the information pages on page 56</a> . Verify that the name, IP address, or Rendezvous host name on the configuration page matches the product name, IP address, or Rendezvous host name in the Print Center.
The interface cable might be defective or of poor quality.	Replace the interface cable. Make sure to use a high-quality cable.

## The printer driver does not automatically set up your selected product in Print Center.

Cause	Solution
The product might not be ready.	Make sure that the cables are connected correctly, the product is on, and the ready light is on. If you are connecting through a USB or Ethernet hub, try connecting directly to the computer or use a different port.
The product software might not have been installed or was installed incorrectly.	Make sure that the PPD file is in the following hard drive folder: <code>Library/Printers/PPDs/Contents/Resources/&lt;lang&gt;.lproj</code> , where “<lang>” represents the two-letter language code for the language that you are using. If necessary, reinstall the software. See the getting started guide for instructions.

### The printer driver does not automatically set up your selected product in Print Center.

Cause	Solution
The product might not be ready.	Make sure that the cables are connected correctly, the product is on, and the ready light is on. If you are connecting through a USB or Ethernet hub, try connecting directly to the computer or use a different port.
The interface cable might be defective or of poor quality.	Replace the interface cable. Make sure to use a high-quality cable.

### A print job was not sent to the product that you wanted.

Cause	Solution
The print queue might be stopped.	Restart the print queue. Open <b>print monitor</b> and select <b>Start Jobs</b> .
The wrong product name or IP address is being used. Another product with the same or similar name, IP address, or Rendezvous host name might have received your print job.	Check the product name, IP address, or Rendezvous host name by printing a configuration page. See <a href="#">Print the information pages on page 56</a> . Verify that the name, IP address, or Rendezvous host name on the configuration page matches the product name, IP address, or Rendezvous host name in the Print Center.

### An encapsulated PostScript (EPS) file does not print with the correct fonts.

Cause	Solution
This problem occurs with some programs.	<ul style="list-style-type: none"><li>Try downloading the fonts that are contained in the EPS file to the product before printing.</li><li>Send the file in ASCII format instead of binary encoding.</li></ul>

### You are unable to print from a third-party USB card.

Cause	Solution
This error occurs when the software for USB devices is not installed.	When adding a third-party USB card, you might need the Apple USB Adapter Card Support software. The most current version of this software is available from the Apple Web site.

When connected with a USB cable, the product does not appear in the Macintosh Print Center after the driver is selected.

Cause	Solution
This problem is caused by either a software or a hardware component.	<p data-bbox="858 302 1118 327"><b>Software problem-solving</b></p> <ul data-bbox="858 352 1430 533" style="list-style-type: none"><li data-bbox="858 352 1302 378">● Check that your Macintosh supports USB.</li><li data-bbox="858 403 1430 457">● Verify that you are using a Macintosh operating system that this product supports.</li><li data-bbox="858 483 1406 533">● Ensure that your Macintosh has the appropriate USB software from Apple.</li></ul> <p data-bbox="858 558 1126 583"><b>Hardware problem-solving</b></p> <ul data-bbox="858 609 1437 1020" style="list-style-type: none"><li data-bbox="858 609 1241 634">● Check that the product is turned on.</li><li data-bbox="858 659 1362 684">● Verify that the USB cable is connected correctly.</li><li data-bbox="858 709 1437 764">● Check that you are using the appropriate high-speed USB cable.</li><li data-bbox="858 789 1437 894">● Ensure that you do not have too many USB devices drawing power from the chain. Disconnect all of the devices from the chain, and connect the cable directly to the USB port on the host computer.</li><li data-bbox="858 919 1437 1020">● Check to see if more than two nonpowered USB hubs are connected in a row on the chain. Disconnect all of the devices from the chain and connect the cable directly to the USB port on the host computer.</li></ul> <p data-bbox="903 1045 1437 1071"><b>NOTE:</b> The iMac keyboard is a nonpowered USB hub.</p>

## Solve Linux problems

For information about Linux problem solving, go to the HP Linux support Web site: [www.hp.com/go/linuxprinting](http://www.hp.com/go/linuxprinting).

---

# A Supplies and accessories

- Order parts, accessories, and supplies
- Part numbers

## Order parts, accessories, and supplies

Several methods are available for ordering parts, supplies, and accessories.

### Order directly from HP

You can obtain the following items directly from HP:

- **Replacement parts:** To order replacement parts in the U.S., go to [www.hp.com/go/hpparts](http://www.hp.com/go/hpparts). Outside the United States, order parts by contacting your local authorized HP service center.
- **Supplies and accessories:** To order supplies in the U.S., go to [www.hp.com/go/ljsupplies](http://www.hp.com/go/ljsupplies). To order supplies worldwide, go to [www.hp.com/ghp/buyonline.html](http://www.hp.com/ghp/buyonline.html). To order accessories, go to [www.hp.com/support/ljp2030series](http://www.hp.com/support/ljp2030series).

### Order through service or support providers

To order a part or accessory, contact an HP-authorized service or support provider.

## Part numbers

The following list of accessories was current at the time of printing. Ordering information and availability of the accessories might change during the life of the product.

### Print cartridges

Item	Description	Part number
HP LaserJet print cartridge	Standard-capacity cartridge	CE505A

### Cables and interfaces

Item	Description	Part number
HP Jetdirect external print server accessories	HP Jetdirect en1700	J7942G
	HP Jetdirect en3700	J7942G
	HP Jetdirect ew2400 USB wireless print server	J7951G
	HP Jetdirect 175x	J6035G
	HP USB network print adapter	Q6275A (worldwide)
	HP wireless printing upgrade kit	Q6236A (North America) Q6259A (Europe, Middle East, Africa, and Asia-Pacific countries/regions)
USB cable	2-meter A to B cable	C6518A
Parallel cables	2-meter IEEE 1284-B cable	C2950A
	3-meter IEEE 1284-B cable	C2951A





---

## B Service and support

- [Hewlett-Packard limited warranty statement](#)
- [Print cartridge limited warranty statement](#)
- [End User License Agreement](#)
- [Customer self-repair warranty service](#)
- [Customer support](#)
- [HP maintenance agreements](#)

# Hewlett-Packard limited warranty statement

HP PRODUCT	DURATION OF LIMITED WARRANTY
HP LaserJet P2035, P2035n	One year from date of purchase

HP warrants to you, the end-user customer, that HP hardware and accessories will be free from defects in materials and workmanship after the date of purchase, for the period specified above. If HP receives notice of such defects during the warranty period, HP will, at its option, either repair or replace products which prove to be defective. Replacement products may be either new or equivalent in performance to new.

HP warrants to you that HP software will not fail to execute its programming instructions after the date of purchase, for the period specified above, due to defects in material and workmanship when properly installed and used. If HP receives notice of such defects during the warranty period, HP will replace software which does not execute its programming instructions due to such defects.

HP does not warrant that the operation of HP products will be uninterrupted or error free. If HP is unable, within a reasonable time, to repair or replace any product to a condition as warranted, you will be entitled to a refund of the purchase price upon prompt return of the product.

HP products may contain remanufactured parts equivalent to new in performance or may have been subject to incidental use.

Warranty does not apply to defects resulting from (a) improper or inadequate maintenance or calibration, (b) software, interfacing, parts or supplies not supplied by HP, (c) unauthorized modification or misuse, (d) operation outside of the published environmental specifications for the product, or (e) improper site preparation or maintenance.

TO THE EXTENT ALLOWED BY LOCAL LAW, THE ABOVE WARRANTIES ARE EXCLUSIVE AND NO OTHER WARRANTY OR CONDITION, WHETHER WRITTEN OR ORAL, IS EXPRESSED OR IMPLIED AND HP SPECIFICALLY DISCLAIMS ANY IMPLIED WARRANTIES OR CONDITIONS OF MERCHANTABILITY, SATISFACTORY QUALITY, AND FITNESS FOR A PARTICULAR PURPOSE. Some countries/regions, states or provinces do not allow limitations on the duration of an implied warranty, so the above limitation or exclusion might not apply to you. This warranty gives you specific legal rights and you might also have other rights that vary from country/region to country/region, state to state, or province to province.

HP's limited warranty is valid in any country/region or locality where HP has a support presence for this product and where HP has marketed this product. The level of warranty service you receive may vary according to local standards. HP will not alter form, fit or function of the product to make it operate in a country/region for which it was never intended to function for legal or regulatory reasons.

TO THE EXTENT ALLOWED BY LOCAL LAW, THE REMEDIES IN THIS WARRANTY STATEMENT ARE YOUR SOLE AND EXCLUSIVE REMEDIES. EXCEPT AS INDICATED ABOVE, IN NO EVENT WILL HP OR ITS SUPPLIERS BE LIABLE FOR LOSS OF DATA OR FOR DIRECT, SPECIAL, INCIDENTAL, CONSEQUENTIAL (INCLUDING LOST PROFIT OR DATA), OR OTHER DAMAGE, WHETHER BASED IN CONTRACT, TORT, OR OTHERWISE. Some countries/regions, states or provinces do not allow the exclusion or limitation of incidental or consequential damages, so the above limitation or exclusion may not apply to you.

THE WARRANTY TERMS CONTAINED IN THIS STATEMENT, EXCEPT TO THE EXTENT LAWFULLY PERMITTED, DO NOT EXCLUDE, RESTRICT OR MODIFY AND ARE IN ADDITION TO THE MANDATORY STATUTORY RIGHTS APPLICABLE TO THE SALE OF THIS PRODUCT TO YOU.

## Print cartridge limited warranty statement

This HP product is warranted to be free from defects in materials and workmanship.

This warranty does not apply to products that (a) have been refilled, refurbished, remanufactured or tampered with in any way, (b) experience problems resulting from misuse, improper storage, or operation outside of the published environmental specifications for the printer product or (c) exhibit wear from ordinary use.

To obtain warranty service, please return the product to place of purchase (with a written description of the problem and print samples) or contact HP customer support. At HP's option, HP will either replace products that prove to be defective or refund your purchase price.

TO THE EXTENT ALLOWED BY LOCAL LAW, THE ABOVE WARRANTY IS EXCLUSIVE AND NO OTHER WARRANTY OR CONDITION, WHETHER WRITTEN OR ORAL, IS EXPRESSED OR IMPLIED AND HP SPECIFICALLY DISCLAIMS ANY IMPLIED WARRANTIES OR CONDITIONS OF MERCHANTABILITY, SATISFACTORY QUALITY, AND FITNESS FOR A PARTICULAR PURPOSE.

TO THE EXTENT ALLOWED BY LOCAL LAW, IN NO EVENT WILL HP OR ITS SUPPLIERS BE LIABLE FOR DIRECT, SPECIAL, INCIDENTAL, CONSEQUENTIAL (INCLUDING LOST PROFIT OR DATA), OR OTHER DAMAGE, WHETHER BASED IN CONTRACT, TORT, OR OTHERWISE.

THE WARRANTY TERMS CONTAINED IN THIS STATEMENT, EXCEPT TO THE EXTENT LAWFULLY PERMITTED, DO NOT EXCLUDE, RESTRICT OR MODIFY AND ARE IN ADDITION TO THE MANDATORY STATUTORY RIGHTS APPLICABLE TO THE SALE OF THIS PRODUCT TO YOU.

# End User License Agreement

PLEASE READ CAREFULLY BEFORE USING THIS SOFTWARE PRODUCT: This End-User License Agreement (“EULA”) is a contract between (a) you (either an individual or the entity you represent) and (b) Hewlett-Packard Company (“HP”) that governs your use of the software product (“Software”). This EULA does not apply if there is a separate license agreement between you and HP or its suppliers for the Software, including a license agreement in online documentation. The term “Software” may include (i) associated media, (ii) a user guide and other printed materials, and (iii) “online” or electronic documentation (collectively “User Documentation”).

RIGHTS IN THE SOFTWARE ARE OFFERED ONLY ON THE CONDITION THAT YOU AGREE TO ALL TERMS AND CONDITIONS OF THIS EULA. BY INSTALLING, COPYING, DOWNLOADING, OR OTHERWISE USING THE SOFTWARE, YOU AGREE TO BE BOUND BY THIS EULA. IF YOU DO NOT ACCEPT THIS EULA, DO NOT INSTALL, DOWNLOAD, OR OTHERWISE USE THE SOFTWARE. IF YOU PURCHASED THE SOFTWARE BUT DO NOT AGREE TO THIS EULA, PLEASE RETURN THE SOFTWARE TO YOUR PLACE OF PURCHASE WITHIN FOURTEEN DAYS FOR A REFUND OF THE PURCHASE PRICE; IF THE SOFTWARE IS INSTALLED ON OR MADE AVAILABLE WITH ANOTHER HP PRODUCT, YOU MAY RETURN THE ENTIRE UNUSED PRODUCT.

1. **THIRD PARTY SOFTWARE.** The Software may include, in addition to HP proprietary software (“HP Software”), software under licenses from third parties (“Third Party Software” and “Third Party License”). Any Third Party Software is licensed to you subject to the terms and conditions of the corresponding Third Party License. Generally, the Third Party License is located in a file such as license.txt; you should contact HP support if you cannot find any Third Party License. If the Third Party Licenses include licenses that provide for the availability of source code (such as the GNU General Public License) and the corresponding source code is not included with the Software, then check the product support pages of HP’s website (hp.com) to learn how to obtain such source code.

2. **LICENSE RIGHTS.** You will have the following rights provided you comply with all terms and conditions of this EULA:

a. **Use.** HP grants you a license to Use one copy of the HP Software. “Use” means installing, copying, storing, loading, executing, displaying, or otherwise using the HP Software. You may not modify the HP Software or disable any licensing or control feature of the HP Software. If this Software is provided by HP for Use with an imaging or printing product (for example, if the Software is a printer driver, firmware, or add-on), the HP Software may only be used with such product (“HP Product”). Additional restrictions on Use may appear in the User Documentation. You may not separate component parts of the HP Software for Use. You do not have the right to distribute the HP Software.

b. **Copying.** Your right to copy means you may make archival or back-up copies of the HP Software, provided each copy contains all the original HP Software’s proprietary notices and is used only for back-up purposes.

3. **UPGRADES.** To Use HP Software provided by HP as an upgrade, update, or supplement (collectively “Upgrade”), you must first be licensed for the original HP Software identified by HP as eligible for the Upgrade. To the extent the Upgrade supersedes the original HP Software, you may no longer use such HP Software. This EULA applies to each Upgrade unless HP provides other terms with the Upgrade. In case of a conflict between this EULA and such other terms, the other terms will prevail.

4. **TRANSFER.**

a. **Third Party Transfer.** The initial end user of the HP Software may make a one-time transfer of the HP Software to another end user. Any transfer will include all component parts, media, User Documentation, this EULA, and if applicable, the Certificate of Authenticity. The transfer may not be an indirect transfer, such as a consignment. Prior to the transfer, the end user receiving the transferred

Software will agree to this EULA. Upon transfer of the HP Software, your license is automatically terminated.

b. Restrictions. You may not rent, lease or lend the HP Software or Use the HP Software for commercial timesharing or bureau use. You may not sublicense, assign or otherwise transfer the HP Software except as expressly provided in this EULA.

5. PROPRIETARY RIGHTS. All intellectual property rights in the Software and User Documentation are owned by HP or its suppliers and are protected by law, including applicable copyright, trade secret, patent, and trademark laws. You will not remove any product identification, copyright notice, or proprietary restriction from the Software.

6. LIMITATION ON REVERSE ENGINEERING. You may not reverse engineer, decompile, or disassemble the HP Software, except and only to the extent that the right to do so is allowed under applicable law.

7. CONSENT TO USE OF DATA. HP and its affiliates may collect and use technical information you provide in relation to (i) your Use of the Software or the HP Product, or (ii) the provision of support services related to the Software or the HP Product. All such information will be subject to HP's privacy policy. HP will not use such information in a form that personally identifies you except to the extent necessary to enhance your Use or provide support services.

8. LIMITATION OF LIABILITY. Notwithstanding any damages that you might incur, the entire liability of HP and its suppliers under this EULA and your exclusive remedy under this EULA will be limited to the greater of the amount actually paid by you for the Product or U.S. \$5.00. TO THE MAXIMUM EXTENT PERMITTED BY APPLICABLE LAW, IN NO EVENT WILL HP OR ITS SUPPLIERS BE LIABLE FOR ANY SPECIAL, INCIDENTAL, INDIRECT, OR CONSEQUENTIAL DAMAGES (INCLUDING DAMAGES FOR LOST PROFITS, LOST DATA, BUSINESS INTERRUPTION, PERSONAL INJURY, OR LOSS OF PRIVACY) RELATED IN ANY WAY TO THE USE OF OR INABILITY TO USE THE SOFTWARE, EVEN IF HP OR ANY SUPPLIER HAS BEEN ADVISED OF THE POSSIBILITY OF SUCH DAMAGES AND EVEN IF THE ABOVE REMEDY FAILS OF ITS ESSENTIAL PURPOSE. Some states or other jurisdictions do not allow the exclusion or limitation of incidental or consequential damages, so the above limitation or exclusion may not apply to you.

9. U.S. GOVERNMENT CUSTOMERS. If you are a U.S. Government entity, then consistent with FAR 12.211 and FAR 12.212, Commercial Computer Software, Computer Software Documentation, and Technical Data for Commercial Items are licensed under the applicable HP commercial license agreement.

10. COMPLIANCE WITH EXPORT LAWS. You will comply with all laws, rules, and regulations (i) applicable to the export or import of the Software, or (ii) restricting the Use of the Software, including any restrictions on nuclear, chemical, or biological weapons proliferation.

11. RESERVATION OF RIGHTS. HP and its suppliers reserve all rights not expressly granted to you in this EULA.

(c) 2007 Hewlett-Packard Development Company, L.P.

Rev. 11/06

## Customer self-repair warranty service

HP products are designed with many Customer Self Repair (CSR) parts to minimize repair time and allow for greater flexibility in performing defective parts replacement. If during the diagnosis period, HP identifies that the repair can be accomplished by the use of a CSR part, HP will ship that part directly to you for replacement. There are two categories of CSR parts: 1) Parts for which customer self repair is mandatory. If you request HP to replace these parts, you will be charged for the travel and labor costs of this service. 2) Parts for which customer self repair is optional. These parts are also designed for Customer Self Repair. If, however, you require that HP replace them for you, this may be done at no additional charge under the type of warranty service designated for your product.

Based on availability and where geography permits, CSR parts will be shipped for next business day delivery. Same-day or four-hour delivery may be offered at an additional charge where geography permits. If assistance is required, you can call the HP Technical Support Center and a technician will help you over the phone. HP specifies in the materials shipped with a replacement CSR part whether a defective part must be returned to HP. In cases where it is required to return the defective part to HP, you must ship the defective part back to HP within a defined period of time, normally five (5) business days. The defective part must be returned with the associated documentation in the provided shipping material. Failure to return the defective part may result in HP billing you for the replacement. With a customer self repair, HP will pay all shipping and part return costs and determine the courier/carrier to be used.

## Customer support

---

Get telephone support, free during your warranty period, for your country/region

Country/region phone numbers are on the flyer that was in the box with your product or at [www.hp.com/support/](http://www.hp.com/support/).

Have the product name, serial number, date of purchase, and problem description ready.

---

Get 24-hour Internet support

[www.hp.com/support/ljp2030series](http://www.hp.com/support/ljp2030series)

---

Get support for products used with a Macintosh computer

[www.hp.com/go/macosex](http://www.hp.com/go/macosex)

---

Download software utilities, drivers, and electronic information

[www.hp.com/go/ljp2030series\\_software](http://www.hp.com/go/ljp2030series_software)

---

Order supplies and paper

[www.hp.com/go/suresupply](http://www.hp.com/go/suresupply)

---

Order genuine HP parts or accessories

[www.hp.com/buy/parts](http://www.hp.com/buy/parts)

---

Order additional HP service or maintenance agreements

[www.hp.com/go/carepack](http://www.hp.com/go/carepack)

---

# HP maintenance agreements

HP has several types of maintenance agreements that meet a wide range of support needs. Maintenance agreements are not part of the standard warranty. Support services may vary by area. Check with your local HP dealer to determine the services available to you.

## On-site service agreements

To provide you with the level of support best suited to your needs, HP has on-site service agreements with a selection of response times.

### Next-day on-site service

This agreement provides support by the next working day following a service request. Extended coverage hours and extended travel beyond HP's designated service zones are available on most on-site agreements (for additional charges).

### Weekly (volume) on-site service

This agreement provides scheduled weekly on-site visits for organizations with many HP products. This agreement is designated for sites using 25 or more workstation products, including devices, plotters, computers, and disk drives.

## Repack the product

If HP Customer Care determines that your product needs to be returned to HP for repair, follow these steps to repack the product before shipping it.

---

△ **CAUTION:** Shipping damage as a result of inadequate packing is the customer's responsibility.

---

1. Remove and retain the print cartridge.

△ **CAUTION:** It is *extremely important* to remove the print cartridge before shipping the product. A print cartridge that remains in the product during shipping can leak and cover the product engine and other parts with toner.

To prevent damage to the print cartridge, avoid touching the roller on it, and store the print cartridge in its original packing material or so that it is not exposed to light.

---

2. Remove and retain the power cable, interface cable, and optional accessories.
3. If possible, include print samples and 50 to 100 sheets of paper or other print media that did not print correctly.
4. In the U.S., call HP Customer Care to request new packing material. In other areas, use the original packing material, if possible. Hewlett-Packard recommends insuring the equipment for shipment.

## Extended warranty

HP Support provides coverage for the HP hardware product and all HP-supplied internal components. The hardware maintenance covers a 1- to 3-year period from date of the HP product purchase. The customer must purchase HP Support within the stated factory warranty. For more information, contact the HP Customer Care Service and Support group.



---

# C Specifications

- [Physical specifications](#)
- [Power consumption and acoustic emissions](#)
- [Operating environment](#)

# Physical specifications

**Table C-1 Product dimensions and weights**

Product model	Height	Depth	Width	Weight
HP LaserJet P2030 Series printer	256 mm (10.1 in)	368 mm (14.5 in)	360 mm (14.2 in)	9.9 kg (21.8 lb)

**Table C-2 Product dimensions with all doors and trays fully opened**

Product model	Height	Depth	Width
HP LaserJet P2030 Series printer	256 mm (10.1 in)	455 mm (17.9 in)	360 mm (14.2 in)

# Power consumption and acoustic emissions

See [www.hp.com/go/ljp2030/regulatory](http://www.hp.com/go/ljp2030/regulatory) for current information.

# Operating environment

**Table C-3 Necessary conditions**

Environmental condition	Printing	Storage/standby
Temperature (product and print cartridge)	7.5° to 32.5°C (45.5° to 90.5°F)	0° to 35°C (32° to 95°F)
Relative humidity	10% to 80%	10% to 90%

---

## D Regulatory information

- [FCC regulations](#)
- [Environmental product stewardship program](#)
- [Declaration of conformity](#)
- [Safety statements](#)

## FCC regulations

This equipment has been tested and found to comply with the limits for a Class B digital device, pursuant to Part 15 of the FCC rules. These limits are designed to provide reasonable protection against harmful interference in a residential installation. This equipment generates, uses, and can radiate radio frequency energy. If this equipment is not installed and used in accordance with the instructions, it may cause harmful interference to radio communications. However, there is no guarantee that interference will not occur in a particular installation. If this equipment does cause harmful interference to radio or television reception, which can be determined by turning the equipment off and on, the user is encouraged to try to correct the interference by one or more of the following measures:

- Reorient or relocate the receiving antenna.
- Increase separation between equipment and receiver.
- Connect equipment to an outlet on a circuit different from that to which the receiver is located.
- Consult your dealer or an experienced radio/TV technician.

---

 **NOTE:** Any changes or modifications to the printer that are not expressly approved by HP could void the user's authority to operate this equipment.

Use of a shielded interface cable is required to comply with the Class B limits of Part 15 of FCC rules.

# Environmental product stewardship program

## Protecting the environment

Hewlett-Packard Company is committed to providing quality products in an environmentally sound manner. This product has been designed with several attributes to minimize impacts on our environment.

## Ozone production

This product generates no appreciable ozone gas (O<sub>3</sub>).

## Power consumption

Power usage drops significantly while in Ready mode, which saves natural resources and saves money without affecting the high performance of this product. To determine the ENERGY STAR® qualification status for this product, see the Product Data Sheet or Specifications Sheet. Qualified products are also listed at:

[www.hp.com/go/energystar](http://www.hp.com/go/energystar)

## Toner consumption

EconoMode uses less toner, which might extend the life of the print cartridge.

## Paper use

This product's manual duplex feature (two-sided printing) and N-up printing (multiple pages printed on one page) capability can reduce paper usage and the resulting demands on natural resources.

## Plastics

Plastic parts over 25 grams are marked according to international standards that enhance the ability to identify plastics for recycling purposes at the end of the product's life.

## HP LaserJet print supplies

It's easy to return and recycle your empty HP LaserJet print cartridges—free of charge—with HP Planet Partners. Multilingual program information and instructions are included in every new HP LaserJet print cartridge and supplies package. You help reduce the toll on the environment further when you return multiple cartridges together rather than separately.

HP is committed to providing inventive, high-quality products and services that are environmentally sound, from product design and manufacturing to distribution, customer use, and recycling. When you participate in the HP Planet Partners program, we ensure your HP LaserJet print cartridges are recycled properly, processing them to recover plastics and metals for new products and diverting millions of tons of waste from landfills. Please note that the cartridge will not be returned to you. Thank you for being environmentally responsible!

 **NOTE:** Use the return label to return original HP LaserJet print cartridges only. Please do not use this label for HP inkjet cartridges, non-HP cartridges, refilled or remanufactured cartridges, or warranty returns. For information about recycling your HP inkjet cartridges, please go to [www.hp.com/recycle](http://www.hp.com/recycle).

## Return and recycling instructions

### United States and Puerto Rico

The enclosed label in the HP LaserJet toner cartridge box is for the return and recycling of one or more HP LaserJet print cartridges after use. Please follow the applicable instructions below.

#### Multiple returns (more than one cartridge)

1. Package each HP LaserJet print cartridge in its original box and bag.
2. Tape the boxes together using strapping or packaging tape. The package can weigh up to 31 kg (70 lb).
3. Use a single pre-paid shipping label.

#### OR

1. Use your own suitable box, or request a free bulk collection box from [www.hp.com/recycle](http://www.hp.com/recycle) or 1-800-340-2445 (holds up to 31 kg (70 lb) of HP LaserJet print cartridges).
2. Use a single pre-paid shipping label.

#### Single returns

1. Package the HP LaserJet print cartridge in its original bag and box.
2. Place the shipping label on the front of the box.

#### Shipping

For all HP LaserJet print cartridge recycling returns, give the package to UPS during your next delivery or pickup, or take it to an authorized UPS drop-off center. For the location of your local UPS drop-off center, call 1-800-PICKUPS or visit [www.ups.com](http://www.ups.com). If you are returning via USPS label, give the package to a U.S. Postal Service carrier or drop off at a U.S. Postal Service Office. For more information, or to order additional labels or boxes for bulk returns, visit [www.hp.com/recycle](http://www.hp.com/recycle) or call 1-800-340-2445. Requested UPS pickup will be charged normal pickup rates. Information subject to change without notice.

#### Non-U.S. returns

To participate in HP Planet Partners return and recycling program, just follow the simple directions in the recycling guide (found inside the packaging of your new product supply item) or visit [www.hp.com/recycle](http://www.hp.com/recycle). Select your country/region for information on how to return your HP LaserJet printing supplies.

#### Paper

This product is capable of using recycled papers when the paper meets the guidelines outlined in the *HP LaserJet Printer Family Print Media Guide*. This product is suitable for the use of recycled paper according to EN12281:2002.

#### Material restrictions

This HP product does not contain added mercury.

This HP product does not contain a battery.

## Disposal of waste equipment by users in private households in the European Union

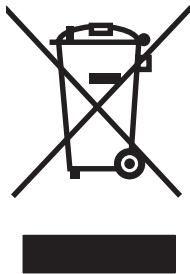

This symbol on the product or on its packaging indicates that this product must not be disposed of with your other household waste. Instead, it is your responsibility to dispose of your waste equipment by handing it over to a designated collection point for the recycling of waste electrical and electronic equipment. The separate collection and recycling of your waste equipment at the time of disposal will help to conserve natural resources and ensure that it is recycled in a manner that protects human health and the environment. For more information about where you can drop off your waste equipment for recycling, please contact your local city office, your household waste disposal service or the shop where you purchased the product.

## Material Safety Data Sheet (MSDS)

Material Safety Data Sheets (MSDS) for supplies containing chemical substances (for example, toner) can be obtained by accessing the HP Web site at [www.hp.com/go/msds](http://www.hp.com/go/msds) or [www.hp.com/hpinfo/community/environment/productinfo/safety](http://www.hp.com/hpinfo/community/environment/productinfo/safety).

## For more information

To obtain information about these environmental topics:

- Product environmental profile sheet for this and many related HP products
- HP's commitment to the environment
- HP's environmental management system
- HP's end-of-life product return and recycling program
- Material Safety Data Sheets

Visit [www.hp.com/go/environment](http://www.hp.com/go/environment) or [www.hp.com/hpinfo/globalcitizenship/environment](http://www.hp.com/hpinfo/globalcitizenship/environment).

# Declaration of conformity

## Declaration of conformity

### Declaration of Conformity

according to ISO/IEC 17050-1 and EN 17050-1, DoC#: BOISB-0801-00-rel.1.0

**Manufacturer's Name:** Hewlett-Packard Company  
**Manufacturer's Address:** 11311 Chinden Boulevard,  
Boise, Idaho 83714-1021, USA

**declares, that the product**

**Product Name:** HP LaserJet P2030 Series

**Regulatory Model Number<sup>2)</sup>:** BOISB-0801-00  
**Product Options:** ALL

Print Cartridges: CE505A

**conforms to the following Product Specifications:**

**Safety:** IEC 60950-1:2001 / EN60950-1: 2001 +A11  
IEC 60825-1:1993 +A1 +A2 / EN 60825-1:1994 +A1 +A2 (Class 1 Laser/LED Product)  
GB4943-2001

**EMC:** CISPR22:2005 / EN 55022:2006 - Class B<sup>1)</sup>  
EN 61000-3-2:2000 +A2  
EN 61000-3-3:1995 +A1  
EN 55024:1998 +A1 +A2  
FCC Title 47 CFR, Part 15 Class B / ICES-003, Issue 4  
GB9254-1998, GB17625.1-2003

### Supplementary Information:

The product herewith complies with the requirements of the EMC Directive 2004/108/EC and the Low Voltage Directive 2006/95/EC, and

carries the CE-Marking  accordingly.

This Device complies with Part 15 of the FCC Rules. Operation is subject to the following two conditions: (1) this device may not cause harmful interference, and (2) this device must accept any interference received, including interference that may cause undesired operation.

1) The product was tested in a typical configuration with Hewlett-Packard Personal Computer Systems.

2) For regulatory purposes, this product is assigned a Regulatory model number. This number should not be confused with the marketing name or the product number(s).

Boise, Idaho , USA

**October 22, 2007**

### For regulatory topics only:

**European Contact:** Your Local Hewlett-Packard Sales and Service Office or Hewlett-Packard GmbH, Department HQ-TRE / Standards Europe., Herrenberger Strasse 140, , D-71034, Böblingen, (FAX: +49-7031-14-3143), <http://www.hp.com/go/certificates>

**USA Contact:** Product Regulations Manager, Hewlett-Packard Company., PO Box 15, Mail Stop 160, Boise, ID 83707-0015, , (Phone: 208-396-6000)



# Safety statements

## Laser safety

The Center for Devices and Radiological Health (CDRH) of the U.S. Food and Drug Administration has implemented regulations for laser products manufactured since August 1, 1976. Compliance is mandatory for products marketed in the United States. The device is certified as a "Class 1" laser product under the U.S. Department of Health and Human Services (DHHS) Radiation Performance Standard according to the Radiation Control for Health and Safety Act of 1968. Since radiation emitted inside the device is completely confined within protective housings and external covers, the laser beam cannot escape during any phase of normal user operation.

△ **WARNING!** Using controls, making adjustments, or performing procedures other than those specified in this user guide may result in exposure to hazardous radiation.

## Canadian DOC regulations

Complies with Canadian EMC Class B requirements.

« Conforme à la classe B des normes canadiennes de compatibilité électromagnétiques. « CEM ». »

## VCCI statement (Japan)

この装置は、情報処理装置等電波障害自主規制協議会（VCCI）の基準に基づくクラスB情報技術装置です。この装置は、家庭環境で使用することを目的としていますが、この装置がラジオやテレビジョン受信機に近接して使用されると、受信障害を引き起こすことがあります。  
取扱説明書に従って正しい取り扱いをして下さい。

## Power cord statement (Japan)

製品には、同梱された電源コードをお使い下さい。  
同梱された電源コードは、他の製品では使用出来ません。

## EMI statement (Korea)

B급 기기 (가정용 정보통신기기)  
이 기기는 가정용으로 전자파적합등록을 한 기기로서  
주거지역에서는 물론 모든지역에서 사용할 수 있습니다.

## Laser statement for Finland

### Luokan 1 laserlaite

Klass 1 Laser Apparat

HP LaserJet P2035, P2035n, laserkirjoitin on käyttäjän kannalta turvallinen luokan 1 laserlaite. Normaalissa käytössä kirjoittimen suojakoteloINTI estää lasersäteen pääsyn laitteen ulkopuolelle. Laitteen turvallisuusluokka on määritetty standardin EN 60825-1 (1994) mukaisesti.

### VAROITUS !

Laitteen käyttäminen muulla kuin käyttöohjeessa mainitulla tavalla saattaa altistaa käyttäjän turvallisuusluokan 1 ylittävälle näkymättömälle lasersäteilylle.

### WARNING !

Om apparaten används på annat sätt än i bruksanvisning specificerats, kan användaren utsättas för osynlig laserstrålning, som överskrider gränsen för laserklass 1.

### HUOLTO

HP LaserJet P2035, P2035n - kirjoittimen sisällä ei ole käyttäjän huollettavissa olevia kohteita. Laitteen saa avata ja huoltaa ainoastaan sen huoltamiseen koulutettu henkilö. Tällaiseksi huoltotoimenpiteeksi ei katsota väriainekasetin vaihtamista, paperiradan puhdistusta tai muita käyttäjän käsikirjassa lueteltuja, käyttäjän tehtäväksi tarkoitettuja ylläpitotoimia, jotka voidaan suorittaa ilman erikoistyökaluja.

### VARO !

Mikäli kirjoittimen suojakotelo avataan, olet alttiina näkymättömälle lasersäteilylle laitteen ollessa toiminnassa. Älä katso säteeseen.

### WARNING !

Om laserprinterns skyddshölje öppnas då apparaten är i funktion, utsättas användaren för osynlig laserstrålning. Betrakta ej strålen. Tiedot laitteessa käytettävän laserdiodin säteilyominaisuuksista: Aallonpituus 775-795 nm Teho 5 m W Luokan 3B laser.

## Substances Table (China)

### 有毒有害物质表

根据中国电子信息产品污染控制管理办法的要求而出台

部件名称	有毒有害物质和元素					
	铅 (Pb)	汞 (Hg)	镉 (Cd)	六价铬 (Cr(VI))	多溴联苯 (PBB)	多溴二苯醚 (PBDE)
打印引擎	X	0	X	X	0	0
控制面板	0	0	0	0	0	0
塑料外壳	0	0	0	0	0	0
格式化板组件	X	0	0	0	0	0
碳粉盒	X	0	0	0	0	0

3043

0：表示在此部件所用的所有同类材料中，所含的此有毒或有害物质均低于 SJ/T11363-2006 的限制要求。

X：表示在此部件所用的所有同类材料中，至少一种所含的此有毒或有害物质高于 SJ/T11363-2006 的限制要求。

注：引用的“环保使用期限”是根据在正常温度和湿度条件下操作使用产品而确定的。



---

# Index

## A

- A6-size paper loading 38
- accessibility features 3
- accessories
  - ordering 108
  - part numbers 109
- acoustic specifications 120
- advanced printing options
  - Windows 53
- alternative letterhead mode 53
- anticounterfeit supplies 60

## B

- batteries included 124
- bins, output
  - capacity 34
  - locating 4
  - selecting 40
- blank pages
  - troubleshooting 100
- booklet printing 52

## C

- cables
  - USB, troubleshooting 100
- Canadian DOC regulations 127
- canceling
  - printing 48
- canceling a print request 48
- card stock
  - output bin, selecting 41
- cartridges
  - authentication 60
  - clean the area 65
  - features 3
  - genuine HP 60
  - non-HP 60, 85
  - order message 85
  - part numbers 109
  - recycling 123

- replace message 85
- replacement intervals 60
- replacing 63
- storage 60
- warranty 113
- cartridges, print
  - Macintosh status 22
- cleaning
  - paper path 67
  - pickup roller (Tray 1) 68
  - pickup roller (Tray 2) 72
  - print-cartridge area 65
  - printer 65
- clearing jams
  - locations 87
  - paper path 87
  - print-cartridge area 87
  - straight-through path 92
  - top output bin 92
  - Tray 1 89
  - Tray 2 90
  - See *also* jams
- colored text
  - print as black 53
- Configuration page 56
- control panel
  - cleaning page, printing 67
  - description 9
  - locating 4
  - settings 13
  - status-light patterns 78
- copies, number of
  - Windows 53
- counterfeit supplies 60
- cover pages 20, 50
- custom paper sizes 32
- custom-size paper settings
  - Macintosh 20

- customer support
  - Linux 106
  - online 117
  - repacking product 118

## D

- declaration of conformity 126
- default settings, restore 77
- Demo page 56
- device discovery over network 25
- device status
  - Macintosh Services tab 22
- dimensions, product 120
- DIMMs
  - accessing 4
- disposal, end-of-life 124
- double-sided printing
  - Macintosh 22
  - See *also* duplex printing
- draft printing 44
- drivers
  - included 3
  - Macintosh settings 20
  - Macintosh, problem-solving 104
  - paper types 33
  - presets (Macintosh) 20
  - Quick Sets(Windows) 49
  - settings 13, 14, 18
  - supported 12
  - Windows, opening 49
- duplex printing
  - Macintosh 22
  - Windows 51
  - See *also* double-sided printing

## E

- EconoMode setting 44
- electrical specifications 120
- embedded Web server 15, 19

- Embedded Web Server (EWS)
  - Information tab 57
  - Networking tab 58
  - order supplies 58
  - product support 58
  - security 58
  - Settings tab 58
  - using 57
- end-of-life disposal 124
- engine communication error message 84
- envelopes
  - loading orientation 36
  - output bin, selecting 41
- environment for the product
  - problem-solving 94
  - specifications 120
- environmental stewardship program 123
- EPS files, problem-solving 105
- Ethernet cards, part numbers 109
- European Union, waste disposal 125
- EWS. See embedded Web server
- extended warranty 118

## F

- FastRes 3
- features 2, 3
- Finnish laser safety statement 128
- first page
  - use different paper 20
- fonts
  - EPS files, problem-solving 105
  - included 3
- formatter
  - security 59
- fraud hotline 60
- fuser
  - errors 84

## G

- General Protection FaultException OE 103

## H

- heavy paper
  - output bin, selecting 41

- HP Customer Care 117
- HP fraud hotline 60
- HP Jetdirect print server
  - part numbers 109
- HP Printer Utility 19
- HP SupportPack 118
- HP-UX software 15
- humidity
  - problem-solving 94
  - specifications 120

## I

- Illegal Operation errors 103
- improve print quality 96
- information pages
  - Configuration page 56
  - Demo page 56
  - Supplies Status page 56
- Information tab (embedded Web server) 57
- input tray
  - loading media 38
- install supplies message 84
- IP address
  - Macintosh, problem-solving 104
  - manual configuration 27
  - protocols supported 25

## J

- jams
  - common causes of 86
  - error messages 84
  - locations 87
  - print quality after 94
  - See also clearing jams
- Japanese VCCI statement 127
- Jetdirect print server
  - part numbers 109

## K

- Korean EMI statement 127

## L

- labels
  - output bin, selecting 41
- landscape orientation
  - setting, Windows 51
- laser safety statements 127, 128
- letterhead paper, loading 53
- license, software 114

- light patterns 78
- link speed settings 27
- Linux drivers 106
- Linux software 15
- loading media
  - A6-size paper 38
  - Tray 1 37
  - Tray 2 38
- lock the product 59

## M

- Macintosh
  - driver settings 18, 20
  - drivers, problem-solving 104
  - HP Printer Utility 19
  - problems, problem-solving 104
  - resize documents 20
  - software 19
  - support 117
  - supported operating systems 18
  - USB card, problem-solving 105
- Macintosh driver settings
  - custom-size paper 20
  - Services tab 22
  - watermarks 21
- maintenance agreements 118
- managing network 26
- manual-feed printing 39
- material restrictions 124
- Material Safety Data Sheet (MSDS) 125
- media
  - custom-size, Macintosh settings 20
  - first page 20
  - pages per sheet 21
  - printing manually 39
  - supported sizes 31
- memory
  - DIMMs, security 59
  - included 19
- mercury-free product 124
- mispick error message 85
- model number 7, 126
- models, feature comparison 2
- multiple pages per sheet
  - Windows 51

## N

- n-up printing
  - Windows 51
- network
  - IP address configuration 27
  - link speed settings 27
  - password, changing 27
  - password, setting 27
  - port, setting up 26
  - product discovery 25
  - protocols supported 25
  - settings, changing 26
  - settings, viewing 26
- network port
  - supported 3
- Networking tab (embedded Web server) 58
- networks
  - configuring 25
- next-day on-site service 118
- non-HP supplies 60, 85

## O

- on-site service agreements 118
- on/off switch, locating 4
- online support 117
- operating environment
  - specifications 120
- operating systems supported 3, 12, 18
- order supplies message 85
- ordering
  - part numbers for 109
  - supplies and accessories 108
- orientation
  - paper, while loading 36
  - setting, Windows 51
- output quality. *See* print quality

## P

- packaging product 118
- page order, changing 53
- page too complex error message 85
- pages
  - blank 100
  - not printing 100
  - per sheet, Windows 51
  - printing slowly 100
- pages per sheet 21

- paper
  - A6-size, tray adjustment 38
  - covers, using different paper 50
  - custom size, selecting 50
  - custom sizes 32
  - custom-size, Macintosh settings 20
  - first and last pages, using different paper 50
  - first page 20
  - loading orientation 36
  - pages per sheet 21
  - problem-solving 94
  - size, selecting 39, 50
  - supported sizes 31
  - supported types 33
  - type, selecting 39, 50
- paper jams. *See* jams
- paper path
  - paper jams 87
- parallel cable, part number 109
- parallel connection 24
- parallel port
  - supported 3
- part numbers
  - print cartridges 109
- pausing a print request 48
- PCL drivers 12
- physical specifications 120
- pickup roller
  - Tray 1 68
  - Tray 2 72
- portrait orientation
  - setting, Windows 51
- ports
  - problem-solving
    - Macintosh 105
  - supported 3, 6
- postcards
  - output bin, selecting 41
- PostScript Printer Description (PPD) files
  - included 19
  - problem-solving 104
- power
  - consumption 120
  - switch, locating 4
  - troubleshooting 76

- PPDs
  - included 19
  - problem-solving 104
- presets (Macintosh) 20
- print cartridges
  - authentication 60
  - clean the area 65
  - features 3
  - genuine HP 60
  - Macintosh status 22
  - non-HP 60, 85
  - order message 85
  - paper jams in area 87
  - part numbers 109
  - recycling 123
  - redistributing toner 62
  - replace message 85
  - replacement intervals 60
  - replacing 63
  - storage 60
  - warranty 113
- print density
  - adjusting 95
- print on both sides
  - Windows 51
- print quality
  - adjust print density 95
  - creases 99
  - curl 98
  - dropouts 96
  - environment 94
  - gray background 97
  - improve 96
  - jams, after 94
  - light or faded print 96
  - loose toner 97
  - misformed characters 98
  - page skew 98
  - paper 94
  - problem-solving 94
  - toner scatter outline 99
  - toner smear 97
  - toner specks 96
  - vertical lines 97
  - vertical repetitive defects 98
  - wave 98
  - wrinkles 99
- print tasks 47
- printer
  - control panel 9

- printer information pages
    - Configuration page 56
    - Demo page 56
    - Supplies Status page 56
  - printing
    - booklets 52
    - Configuration page 56
    - connect to a network 26
    - Demo page 56
    - manual feed 39
    - Supplies Status page 56
    - troubleshooting 100
  - priority, settings 13
  - problem-solving
    - environment 94
    - EPS files 105
    - Linux 106
    - Macintosh problems 104
    - output quality 94
    - paper 94
    - status-light patterns 78
    - See also* solving; troubleshooting
  - processor speed 3
  - product comparison 2
  - protocols, networks 25
- Q**
- quality. *See* print quality
  - Quick Sets 49
  - quiet mode
    - enabling 45
- R**
- rear output
    - bin, locating 4
    - printing to 41
  - recycling
    - HP printing supplies returns and environmental program 124
  - redistributing toner 62
  - repacking product 118
  - replace supplies message 85
  - replacing printing cartridges 63
  - resize documents
    - Macintosh 20
    - Windows 50
  - resolution
    - features 3
    - problem-solving quality 94
  - rough paper
    - output bin, selecting 41
- S**
- safety statements 127, 128
  - scale documents
    - Macintosh 20
    - Windows 50
  - scanner error message 84
  - security features 59
  - serial number 7
  - service
    - repacking product 118
  - service agreements 118
  - Services tab
    - Macintosh 22
  - settings
    - driver presets (Macintosh) 20
    - drivers 14, 18
    - network printing 26
    - priority 13
  - Settings tab (embedded Web server) 58
  - shipping product 118
  - small paper, printing on 41
  - software
    - embedded Web server 15, 19
    - HP Printer Utility 19
    - Macintosh 19
    - settings 13
    - software license agreement 114
    - supported operating systems 12, 18
    - uninstalling for Windows 14
  - Solaris software 15
  - solving
    - creases 99
    - curl 98
    - direct-connect problems 101
    - dropouts 96
    - gray background 97
    - light or faded print 96
    - loose toner 97
    - misformed characters 98
    - network problems 101
    - page skew 98
    - toner scatter outline 99
    - toner smear 97
  - toner specks 67, 96
  - vertical lines 97
  - vertical repetitive defects 98
  - wave 98
  - wrinkles 99
  - See also* problem-solving; troubleshooting
- special media
  - guidelines 35
- special paper
  - guidelines 35
- specifications
  - electrical and acoustic 120
  - features 3
  - operating environment 120
  - physical 120
- Spool32 errors 103
- status
  - Macintosh services tab 22
- status-light patterns 78
- stopping a print request 48
- storing
  - print cartridges 60
- straight-through paper path
  - paper jams 92
- supplies
  - authentication 60
  - counterfeit 60
  - non-HP 60, 85
  - order message 85
  - ordering 108
  - part numbers 109
  - recycling 123
  - replace message 85
  - replacement intervals 60
  - replacing print cartridges 63
  - Supplies Status page 56
  - supply-status, Services tab
    - Macintosh 22
    - Windows 52
- support
  - Linux 106
  - online 52, 117
  - repacking product 118
  - supported media 31
  - SupportPack, HP 118
- T**
- TCP/IP
    - protocols supported 25



- technical support
  - Linux 106
  - online 117
  - repacking product 118
- temperature specifications 120
- toner
  - loose toner 97
  - low 96
  - redistributing 62
  - scatter outline 99
  - smear 97
  - specks 67, 96
- toner cartridges. *See* print cartridges
- top output bin
  - capacity 34
  - locating 4
  - paper jams 92
  - printing to 40
- transparencies
  - output bin 40
- Tray 1
  - capacity 34
  - loading 37
  - paper jams 89
- Tray 2
  - capacity 34
  - loading 38
  - paper jams 90
- trays
  - capacity 34
  - configure 39
  - double-sided printing 22
  - locating 4
  - paper orientation 36
- troubleshooting
  - blank pages 100
  - checklist 76
  - direct-connect problems 101
  - network problems 101
  - pages not printing 100
  - pages printing slowly 100
  - paper jams 87, 89, 90, 92
  - paper pickup (Tray 1) 68
  - paper pickup (Tray 2) 72
  - USB cables 100
  - See also* solving; problem-solving
- two-sided printing
  - Windows 51

**U**

- uninstalling Windows software 14
- UNIX software 15
- USB cable, part number 109
- USB connection 24
- USB port
  - problem-solving
    - Macintosh 105
    - supported 3
  - troubleshooting 100

**W**

- warranty
  - customer self repair 116
  - extended 118
  - license 114
  - print cartridges 113
  - product 112
- watermarks
  - Windows 50
- Web server, embedded 57
- Web sites
  - customer support 117
  - fraud reports 60
  - Linux support 106
  - Macintosh customer support 117
  - Material Safety Data Sheet (MSDS) 125
  - ordering supplies 108
- weekly on-site service 118
- weight, product 120
- Windows
  - driver settings 14
  - drivers supported 12
  - supported operating systems 12





© 2008 Hewlett-Packard Development Company, L.P.

[www.hp.com](http://www.hp.com)



CE461-90902